

VEHICLE DETAILS

Chassis number ¹: ZRR70-0537007

Manufacture date: 2012-11

Make: TOYOTA

Model: NOAH

Body: DBA-ZRR70G

Grade: X G EDITION

Engine: 3ZR

Drive: 2WD

Transmission: AT

Title information ²:



Deregistered to Export



Accident / Repair:



No problem



Odometer rollback:



No problem



Manufacturer recall:



No problem



Safety grade ³:



★★★★★



Contamination risk:



No problem



This vehicle does not qualify for Buyback Guarantee

Average Market Price



Unfortunately, this vehicle does not qualify for our Buyback Guarantee program.



¥0

[About Buyback Guarantee](#)

This CAR VX Vehicle History Report is based only on Information supplied to CAR VX, LTD and available as of 2024-02-08 03:17:35. Other information about this vehicle, including problems, may not have been reported to CAR VX, LTD . Use this report as one important tool, along with a vehicle inspection and test drive, to make a better decision about your next used car.

ACCIDENT / REPAIR HISTORY

| Problem type | Reported | Date reported | Data source | Details | Airbag |
|--------------|--------------|---------------|-------------|---------|--------|
| Collision | Not reported | | | | |
| Malfunction | Not reported | | | | |
| Theft | Not reported | | | | |
| Fire damage | Not reported | | | | |
| Water damage | Not reported | | | | |
| Hail damage | Not reported | | | | |

ODOMETER READINGS HISTORY

| Date reported | Data source | Odometer reading (Km) |
|---------------|-------------|-----------------------|
| 2019-12-03 | MLIT | 47800 |
| 2021-12-15 | MLIT | 62100 |
| 2023-12-07 | USS Tokyo | 78019 |
| 2023-12-12 | JU Saitama | 78023 |
| 2023-12-15 | USS Saitama | 78025 |

USE HISTORY

| | | |
|---|---|-----------------------|
| Use in the contaminated regions ⁴ | Radioactive contamination test fail ⁵ | Commercial use |
| Not reported | Not reported | Not reported |

DETAILED HISTORY

| Event date | Location | Odometer reading (Km) | Data source | Details |
|------------|----------|-----------------------|-------------|--------------------|
| 2012-11 | | | TOYOTA | Manufactured |
| 2012-12 | | | MLIT | First registration |
| 2019-12-03 | | 47800 | MLIT | Inspection |

| | | | | |
|------------|---------|-------|-------------|-------------------|
| 2021-12-15 | Omiya | 62100 | MLIT | Inspection |
| 2023-12-05 | Omiya | | MLIT | Last registration |
| 2023-12-07 | Chiba | 78019 | USS Tokyo | Auctioned |
| 2023-12-12 | Saitama | 78023 | JU Saitama | Auctioned |
| 2023-12-15 | Saitama | 78025 | USS Saitama | Auctioned |

MANUFACTURER RECALL HISTORY

| Date reported | Data source | Affected part | Details |
|---|-------------|---------------|---------|
|  Not reported | | | |

VEHICLE ASSESSMENT ⁶

Overall Collision Safety Ratings

| Driver's seat | | | Front passenger's seat | | |
|---------------|------------|--------------|------------------------|------------|--------------|
| Points | Evaluation | Goal average | Points | Evaluation | Goal average |
| 33.25 | ★★★★★★ | 92% | 21.78 | ★★★★★★ | 91% |

* In order to accurately differentiate between the evaluations of different vehicles, a standard is set based on current technology. Up to 6 points out of 12 is given level 1 and the rest of the range is divided up into equal parts, which are respectively assigned to level 2 (more than 6 points but 7.5 or less), level 3 (more than 7.5 points but 9 or less), level 4 (more than 9 points but 10.5 or less) or level 5 (more than 10.5 points).

Braking performance tests ⁷

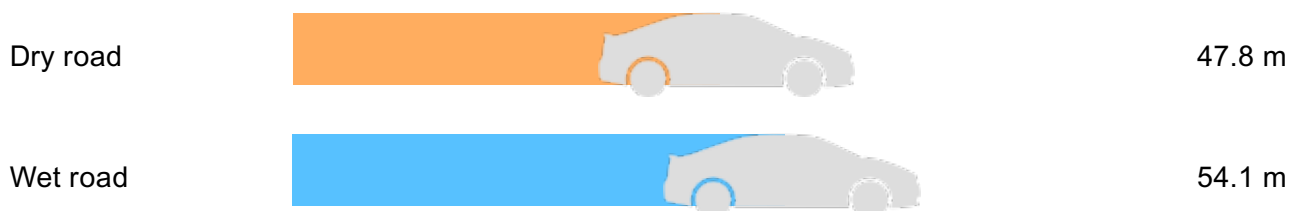

VEHICLE SPECIFICATION

| | | | |
|-----------------------|--|-----------------------|---|
| 1st gear ratio | 2.396 ~ 0.428(MANUAL MODE ATTACHING): CONTINUOUSLY VARIABLE TRANSMISSION | 2nd gear ratio | - |
| 3rd gear ratio | - | 4th gear ratio | - |

| | | | |
|--|---|---------------------------------------|--|
| 5th gear ratio | - | 6th gear ratio | - |
| Additional notes | APXEP | Airbag position, capacity | - |
| Body rear overhang | 895 | Body type | MV&1BOX |
| Chassis number embossing position | COWL TOP PANEL CENTRE | Classification code | 0160 |
| Cylinders | 4 | Displacement | 1980 |
| Electric engine type | - | Electric engine maximum output | - |
| Electric engine maximum torque | - | Electric engine power | - |
| Engine maximum power | 116/6200(NET) | Engine maximum torque | 196/4400(NET) |
| Engine model | 3ZR | Frame type | SOLID STRUCTURE |
| Front shaft weight | 890 | Front shock absorber type | |
| Front stabilizer type | TORSION BAR TYPE | Front tires size | 195/65R15 91SGOODYEARGT065 195/65R15 91STOYOJ31 |
| Front tread | 1.480 | Fuel consumption | 14.4 |
| Fuel tank equipment | 60 | Grade | X G EDITION |
| Height | 1.850 | Length | 4.595 |
| Main brakes type | HYDRAULIC TYPE, FRONT: DISK BACK: LEADING TRAILING HYDRAULIC TYPE, FRONT: DISK BACK: DISK | Make | TOYOTA |
| Maximum speed | 180 | Minimum ground clearance | 0.165 |

| | | | |
|-------------------------------|------------------|---------------------------------|--|
| Minimum turning radius | 5.5 | Model | NOAH |
| Model code | DBA-ZRR70G | Mufflers number | |
| Rear shaft weight | 700 | Rear shock absorber type | |
| Rear stabilizer type | TORSION BAR TYPE | Rear tires size | 195/65R15 91SGOODYEARGT065 195/65R15 91STOYOJ31 |
| Rear tread | 1.470 1.475 | Reverse ratio | 1.668 |
| Riding capacity | 7 | Side brakes type | MACHINE CAR WHEEL 制動 SHAPE(DRUM TYPE) |
| Specification code | 15737 | Stopping distance | 52(100) |
| Transmission type | AT | Weight | 1590 |
| Wheel alignment | 2WD | Wheelbase | 2.825 |
| Width | 1.695 | | |

AUCTION DATA

Date: 2023-12-07, Auction: USS Tokyo, Lot #: 26442

| | | | |
|---------------------------|---------------------------|-----------------------|--------|
| Date: | 2023-12-07 | Lot #: | 26442 |
| Auction name: | USS Tokyo | Region: | Chiba |
| Make: | TOYOTA | Model: | NOAH |
| Reg. year: | 2012 | Mileage (km): | 78019 |
| Displacement (cc): | 2000 | Transmission: | AT |
| Color: | PURPLE | Model code: | ZRR70G |
| Result: | available | Auction grade: | 4 |
| Problem type: | No problem | Problem scale: | None |
| Contaminated: | No | Airbag: | OK |

Date: 2023-12-12, Auction: JU Saitama, Lot #: 5135

| | | | |
|--------------------|----------------------------|----------------|---------|
| Date: | 2023-12-12 | Lot #: | 5135 |
| Auction name: | JU Saitama | Region: | Saitama |
| Make: | TOYOTA | Model: | NOAH |
| Reg. year: | 2012 | Mileage (km): | 78023 |
| Displacement (cc): | 2000 | Transmission: | AT |
| Color: | PURPLE | Model code: | ZRR70G |
| Result: | unsold | Auction grade: | 4 |
| Problem type: | No problem | Problem scale: | None |
| Contaminated: | No | Airbag: | OK |

Date: 2023-12-15, Auction: USS Saitama, Lot #: 2093

| | | | |
|--------------------|-----------------------------|----------------|---------|
| Date: | 2023-12-15 | Lot #: | 2093 |
| Auction name: | USS Saitama | Region: | Saitama |
| Make: | TOYOTA | Model: | NOAH |
| Reg. year: | 2012 | Mileage (km): | 78025 |
| Displacement (cc): | 2000 | Transmission: | AT |
| Color: | PURPLE | Model code: | ZRR70G |
| Result: | available | Auction grade: | 4 |
| Problem type: | No problem | Problem scale: | None |
| Contaminated: | No | Airbag: | OK |

PHOTOS AND AUCTION SHEETS

プライムコーナー

| | | | | |
|-------|---------------|-----|----------|---------|
| 26442 | 車種 (自動車以外は記入) | 排気量 | 型式 | 押込点 |
| | 初年度登録年月 | 車名 | グレード | 4 |
| | 2/12月 | 17 | 5 XGエンジン | 内容 C |

| | | | | | | | | | |
|------|---------|-----|----------------|-----|----------|-----|-----|-----|-----|
| 車検 | 年 | 月 | シフト | AT | 特 | S R | MAW | E S | P W |
| 走行 | 78,019 | km | 冷房 | AC | 高 | カワ | TV | ナビ | ETB |
| 外 元色 | 色替 | カラー | 有・無 | 有・無 | セールスポイント | | | | |
| 色 | 3-710 | 389 | | | 2-サ-買取車! | | | | |
| 燃料 | ガソリン・軽油 | 内装色 | 2サ+ナビ・ナビ・ナビ・ナビ | | | | | | |

| | | | | | |
|-----------------------|--------|------|----|-------|---------|
| リサイクル 増税金 | 12530円 | 乗車定員 | 7人 | 登録地 | |
| 注意事項 (修復・不具合箇所および状態等) | | | | 車台号 | 0537007 |
| ディーラー出品! | | | | シリアル号 | |

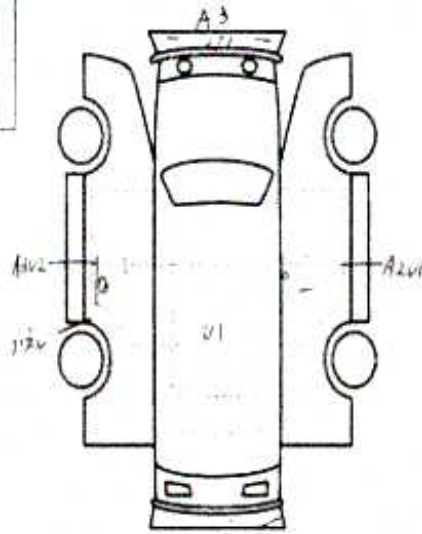

検査員報告 (USS使用欄)

ハンドルAT
116キス
ルーム内を剥ぐ22 新物
外装1-16
左テカ1-18

各キス出フキス

| | | | |
|------|---|----|-------------|
| 台内寸約 | X | X | () |
| 寸 | 幅 | 高さ | ● (車検証上の寸法) |





| | | | | |
|------------------------------|------------------|--------------------------|---|-----------------------------|
| 出品番号 [2111] 5135 | 初度登録年月 24 12月 | 車名・グレード 1.7 X Gエディション | 2WD 4WD | 評価点 4 |
| 型式 DBA-ZRR70G | 排気量 2000 CC | ドア 5 | 定員 7人 | ディーラー・並行 モビル 年式 kg |
| 車歴 自家用・() | シフト AT | 形状 W | 積載 | 外装 C |
| 車検 年 月(日) | 冷房 AAC | 燃料 ガソリン 軽油 | セールスポイント (正常に機能するものに限りです) Xモリ-ナビ、TVナビ、BEニター 両側107-スライドドア、7人乗り エアDIR-シ、クAW、70リジスタート | 内装 C |
| 走行 7万8千023 km | 色 10-701L | 色替 色コード 3R9 | 装備品 (純正品に限り○をつけてください) | 新車保証書 有・無 |
| R券 12530 円 | 名変期限 月 日 | SR | PS | SR |
| 注意事項申告欄 (不具合内容等は具体的に記入して下さい) | | SR | ナビ | SR |
| 修復歴 有 [箇所] | | SR | TV | SR |
| 検査員 記入欄 | | SR | カワ | SR |
| FW | | SR | AW | SR |
| キズ・飛石・ヒビ割・リペア跡・X要 | | SR | AW | SR |
| 内装 | | SR | AW | SR |
| キズ・汚損・コゲ・穴・破れ・キレ・破れ | | SR | AW | SR |

検査員
記入欄

レストモ布
シートシミ、ス
ハンドルスレ
キズEスリキズ
サイドカバンキズ、ハコミ

| | | | | |
|----|----|-----|-----|----|
| PS | PW | ABS | エアB | AW |
| SR | ナビ | TV | カワ | SR |

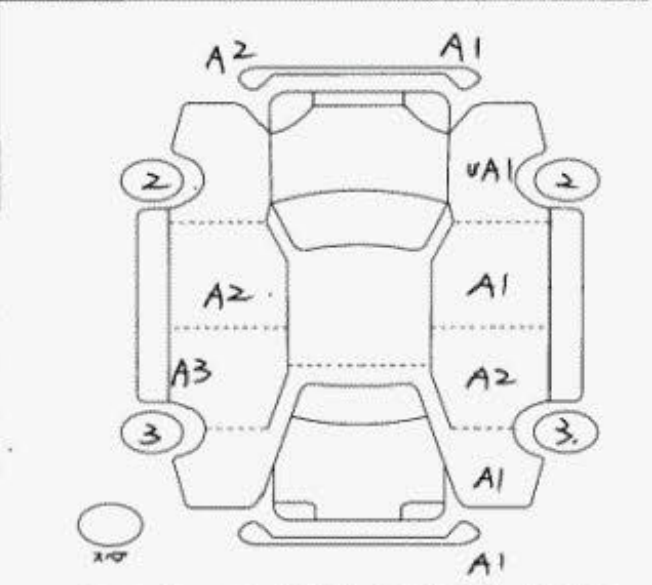

| | |
|------|---------------|
| 車台番号 | ZRR70-0537007 |
| 登録番号 | |

| | |
|--------|--------|
| 型式指定番号 | 類別区分番号 |
| 車庫証明用 | 長さ |
| 長さ | 幅 |
| 高さ | 高さ |
| 長さ | 高さ |





グリーンコーナー

| | | | |
|------------|-------------------|------------|----------|
| 2093 | 車歴 (前車歴以外は記入) 研究費 | 型式 | 所在地 |
| | 2111 | DBA-ZRR04G | 4 |
| 初年度登録年月 車名 | グレード | 2WD | 内装 色目 |
| 24/12月 17 | 5W X Eタイプ | 4WD | |

| | | | | | | | | | |
|------------------------|-------|-----|-----|-----|------|---|-----|----|----|
| 車種 | 年 | 月 | ソフト | AT | 特 | SR | MAW | R9 | R0 |
| 走行 | 1.8 | √ | 25 | 冷房 | AAC | セルナビ | ナビ | ナビ | ナビ |
| 外色 | 色目 | カラー | 3R9 | 有・無 | 有・無 | XE1-1000000, PE-9- 可換(107-スラット) (7人乗) EY12915010-4, 5+10-9- 7122RPT, スラット, グラウ | | | |
| リサイクル 標記 | 12510 | 円 | 7人 | 登録地 | 車台 | ZRR01-1539119 | | | |
| ○注意事項 (車庫 不具合箇所および修理等) | | | | | シリアル | | | | |

検査員報告 (USS使用欄)

4-4月13日 No.10
 R20017
 72277-?
 42-117

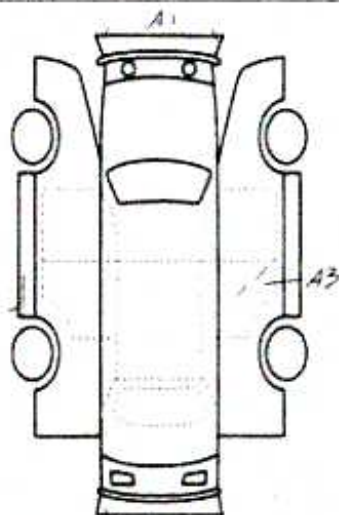

[荷台内寸] 約 X X (cm)
 長さ □ 幅 □ 高さ □ (車体上の寸法)

※必ず適正なオイルメンテナンスを定期的に行ってください。また、オイルレベルは定期的に確認してください。



¹ Chassis number – a unique identification number of the vehicle in Japan (same as VIN in the USA or Europe)

² Title information:

Registered – qualified for driving in Japan

Deregistered Temporarily – not qualified for driving in Japan, usually a temporary title during the ownership change

Deregistered Completely – not qualified for driving in Japan, the vehicle is determined to be scrapped

Deregistered to Export – not qualified for driving in Japan, the vehicle is determined to be exported

³ Determining the overall collision safety performance evaluation – For the driver's seat, the results of the full-wrap frontal collision test, offset frontal collision test, and side collision test are added together and evaluated to 6 different levels. For the Frontal passenger's seat, the results of the full-wrap frontal collision test and the side collision test (results for the driver's or the front passenger's seat are used) are added together and evaluated to 6 different levels.

Regular vehicle inspection – All vehicles in Japan must undergo regular vehicle inspections (shaken). New cars need to be tested after three years, and then vehicles must be tested every two years thereafter. A vehicle inspection (shaken) is compulsory for all vehicles with an engine size over 250cc. It ensures that all vehicles on the road are properly maintained and safe to drive. The test also checks that vehicles have not been illegally modified; if they are found to have been modified, they are not allowed on the road.

⁴ Use in the contaminated regions – The Fukushima Daiichi nuclear disaster was a catastrophic failure at the Fukushima I Nuclear Power Plant on 11 March 2011, resulting in a meltdown of three of the plant's six nuclear reactors. As a result, some areas in the following prefectures were contaminated: Fukushima, Miyagi, Ibaraki, Tochigi.

⁵ Radioactive contamination test – radioactive contamination inspection that was started in July 2011 as a preventive measure for exporting contaminated vehicles from Japan. The inspection is being conducted since in all sea ports of Japan under the supervision of The Japan Harbor Transportation Association (JHTA).

MLIT – Ministry of Land, Infrastructure, Transport and Tourism.

⁶ Japan New Car Assessment Program – the Ministry of Land, Infrastructure, Transport and Tourism (MLIT) and the National Agency for Automotive Safety & Victims' Aid (NASVA) have taken measures for safety, one of which is to assess commercially available vehicles through a variety of safety performance tests and release the resulting information compiled into the "New Car Assessment Program". The objective of Japan New Car Assessment Program is to increase the use of safe automobiles by providing an environment in which users can easily select such vehicles. This also promotes the development of safer vehicles by automobile manufacturers. Neck injury protection for rear-end collision performance test, rear seat passenger's protection for frontal collision performance test, rear passenger's seat belt usability evaluation test and seat belt reminder for passengers evaluation test are started in FY2009.

⁷ Braking Performance Tests – Braking performance is determined by the shortness of the distance in which a vehicle can stop and the stability of the vehicle at the time of braking. This test is performed under wet and dry road conditions for a vehicle which has both a driver and a front passenger. The distance it takes for the vehicle to stop and the stability of the vehicle at the time of braking is evaluated for when the vehicle is stopped abruptly while traveling at a speed of 100km/h. The stopping distance and vehicle speed have been measured by using GPS since FY2009.

CAR VX, LTD DEPENDS ON ITS SOURCES FOR THE ACCURACY AND RELIABILITY OF ITS INFORMATION. THEREFORE, NO RESPONSIBILITY IS ASSUMED BY CAR VX, LTD OR ITS AGENTS FOR ERRORS OR OMISSIONS IN THIS REPORT. CAR VX, LTD FURTHER EXPRESSLY DISCLAIMS ALL WARRANTIES, EXPRESS OR IMPLIED, INCLUDING ANY IMPLIED WARRANTIES OF MERCHANTABILITY OR FITNESS FOR A PARTICULAR PURPOSE.

© 2014-2024 Car VX Limited. All rights reserved.