



Vehicle History Report

VEHICLE DETAILS

Chassis number ¹: AVV50-1014720

Manufacture date: 2012-04

Make: TOYOTA

Model: CAMRY

Body: DAA-AVV50

Grade: HYBRID G PACKAGE

Engine: 2AR-2JM

Drive: 2WD

Transmission: AT

Title information ²:



Deregistered to Export



Accident / Repair:



No problem



Odometer rollback:



No problem



Manufacturer recall:



No problem



Safety grade ³:



No data



Contamination risk:



No problem



This vehicle does not qualify for Buyback Guarantee

Average Market Price



Unfortunately, this vehicle does not qualify for our Buyback Guarantee program.



¥0

[About Buyback Guarantee](#)

This CAR VX Vehicle History Report is based only on Information supplied to CAR VX, LTD and available as of 2024-03-07 01:09:38. Other information about this vehicle, including problems, may not have been reported to CAR VX, LTD . Use this report as one important tool, along with a vehicle inspection and test drive, to make a better decision about your next used car.

ACCIDENT / REPAIR HISTORY

Problem type	Reported	Date reported	Data source	Details	Airbag
Collision	Not reported				
Malfunction	Not reported				
Theft	Not reported				
Fire damage	Not reported				
Water damage	Not reported				
Hail damage	Not reported				

ODOMETER READINGS HISTORY

Date reported	Data source	Odometer reading (Km)
2021-03-29	MLIT	48100
2023-03-31	MLIT	55700
2024-02-08	TAA Kantou	58197
2024-02-14	MIRIVE Saitama	58197

USE HISTORY

Use in the contaminated regions ⁴	Radioactive contamination test fail ⁵	Commercial use
Not reported	Not reported	Not reported

DETAILED HISTORY

Event date	Location	Odometer reading (Km)	Data source	Details
2012-04			TOYOTA	Manufactured
2012-04			MLIT	First registration
2021-03-29		48100	MLIT	Inspection
2023-03-31	Yokohama	55700	MLIT	Inspection

2024-02-08	Chiba	58197	TAA Kantou	Auctioned
2024-02-14		58197	MIRIVE Saitama	Auctioned
2024-02-22	Yokohama		MLIT	Last registration

MANUFACTURER RECALL HISTORY

Date reported	Data source	Affected part	Details
---------------	-------------	---------------	---------

 Not reported

VEHICLE ASSESSMENT ⁶

Overall Collision Safety Ratings

Driver's seat			Front passenger's seat		
Points	Evaluation	Goal average	Points	Evaluation	Goal average
0		0%	0		0%

* In order to accurately differentiate between the evaluations of different vehicles, a standard is set based on current technology. Up to 6 points out of 12 is given level 1 and the rest of the range is divided up into equal parts, which are respectively assigned to level 2 (more than 6 points but 7.5 or less), level 3 (more than 7.5 points but 9 or less), level 4 (more than 9 points but 10.5 or less) or level 5 (more than 10.5 points).

Braking performance tests ⁷

Dry road 

Wet road 

VEHICLE SPECIFICATION

1st gear ratio	-	2nd gear ratio	-
3rd gear ratio	-	4th gear ratio	-
5th gear ratio	-	6th gear ratio	-

Additional notes	AEXNB	Airbag position, capacity	DRIVER:FRONT:45,210 /16,250 DRIVER:SIDE:13,170 PASSENGER:FRONT:10
Body rear overhang	1005	Body type	SEDAN
Chassis number embossing position	FRONT FLOOR CROSSMEMBER RIGHT SIDE ON SURFACE	Classification code	0001
Cylinders	4 WIDTH	Displacement	2490
Electric engine type	SAME PERIOD ELECTRIC MACHINE	Electric engine maximum output	105/4500
Electric engine maximum torque	270/0 ~ 1500	Electric engine power	24.0
Engine maximum power	118/5700(NET)	Engine maximum torque	213/4500(NET)
Engine model	2AR-2JM	Frame type	SOLID STRUCTURE
Front shaft weight	930	Front shock absorber type	
Front stabilizer type	TORSION BAR TYPE	Front tires size	215/60R16 95H 16 -INCH TIRE ATTACHING 215/55R17 93V 17 -INCH TIRE ATTACHING
Front tread	1.575	Fuel consumption	26.5
Fuel tank equipment	65	Grade	HYBRID G PACKAGE
Height	1.470	Length	4.825
Main brakes type	OIL PRESSURE · TIMES BRAKE TYPE, FRONT: DISK BACK: DISK	Make	TOYOTA
Maximum speed	180	Minimum ground clearance	0.150
Minimum turning radius	5.5	Model	CAMRY

Model code	DAA-AVV50	Mufflers number	
Rear shaft weight	610	Rear shock absorber type	
Rear stabilizer type	TORSION BAR TYPE	Rear tires size	215/60R16 95H 16 -INCH TIRE ATTACHING 215/55R17 93V 17 -INCH TIRE ATTACHING
Rear tread	1.565	Reverse ratio	-
Riding capacity	5	Side brakes type	MACHINE CAR WHEEL SHAPE(DRUM TYPE)
Specification code	16968	Stopping distance	50(100)
Transmission type	AT	Weight	1540
Wheel alignment	2WD	Wheelbase	2.775
Width	1.825		

AUCTION DATA

Date: 2024-02-08, Auction: TAA Kantou, Lot #: 72053

Date:	2024-02-08	Lot #:	72053
Auction name:	TAA Kantou	Region:	Chiba
Make:	TOYOTA	Model:	CAMRY
Reg. year:	2012	Mileage (km):	58197
Displacement (cc):	2500	Transmission:	FAT
Color:	SILVER	Model code:	AVV50
Result:	unsold	Auction grade:	3
Problem type:	No problem	Problem scale:	None
Contaminated:	No	Airbag:	OK

Date: 2024-02-14, Auction: MIRIVE Saitama, Lot #: 15153

Date:	2024-02-14	Lot #:	15153
-------	------------	--------	-------

Auction name:	MIRVE Saitama	Region:	
Make:	TOYOTA	Model:	CAMRY
Reg. year:	2012	Mileage (km):	58197
Displacement (cc):	2500	Transmission:	FAT
Color:	SILVER	Model code:	AVV50
Result:	sold	Auction grade:	4
Problem type:	No problem	Problem scale:	None
Contaminated:	No	Airbag:	OK

PHOTOS AND AUCTION SHEETS

出品番号	初度登録	車名	ドア形状	グレード	評価点
72053	H ²⁴ 年	カムリ	4SD	ハイブリッド Gパッケージ	3
	4月	自家用	2500cc	ガソリン	型式 DAA-AVV50
					外装 内装 E C

走行	車検	登録番号	名変期限	セールスポイント	
58,197 km	07年04月	群馬 330タ6826	月 日	★オークションデビュー★ プッシュスタート バックモニター	
シフト	エアコン	外装色	乗車定員	最大積載量	
FAT	AAC	シルバー	5人	kg	
		カラーNo.	輸入車	リサイクル預託金	
		1F7	グレ系	12,500円	
後日発送部品				純正装備	
				ABS イアB アルミ PS PW	

注意事項欄			車台番号		
			AVV50-1014720		
			諸元		
長さ		幅	高さ		

検査員記入欄
外装色あせ ドア内張りしみ中 シートへたり タッチP跡 Fガラス気泡
事務局よりご案内
◆北関東ヤード◆群馬県前橋市西大室町1257-6

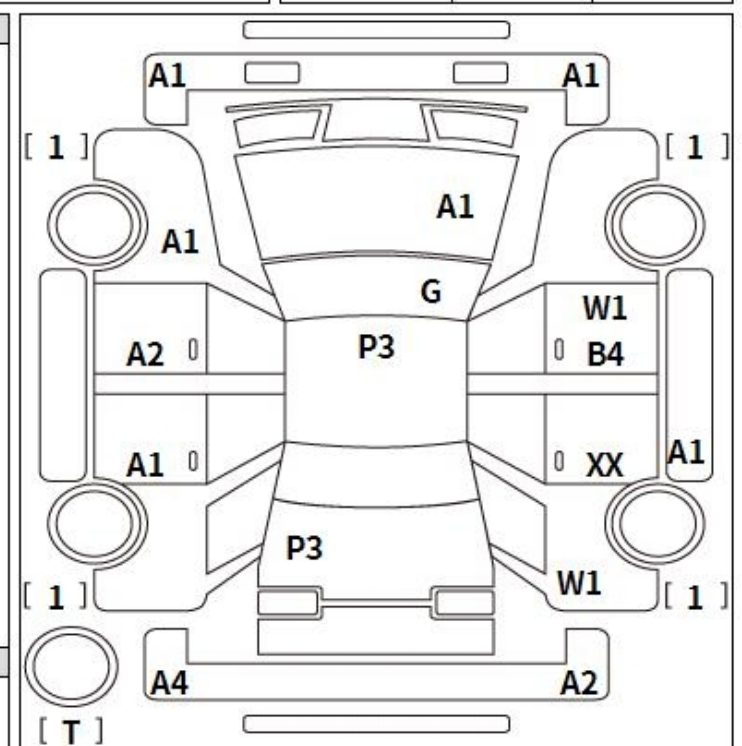

A: 板 U: 穴 B: 穴を伴う穴 P: 要塗装 W: 補修跡 S: 錆 C: 腐食 G: 7D以外5点板 XX: 交換済み X: 要交換 内・外装評価 5段階評価(A・B・C・D・E) 2



出品番号 [1219] 15153	初年度登録 H24 4	車名 カムリセダン	ドア 4	グレード ハイブリッドGパッケージ	駆動 4WD	評価点
埼玉	2012	型式 DAA - AVV50	排気量 2,500	保証年 有・無	定員 5	4

走行 58197 km	車検 7 4	色 (Col.No) シルバー	燃料 ◎ D・電気 (その他)	外装 C	内装 C
----------------	-----------	--------------------	--------------------	---------	---------

シート FAT	エアコン AAC	リサイクル預託金 12,500	PS	PW	AW	エアB	ABS	革	SR	ナビ	DTV
------------	-------------	--------------------	----	----	----	-----	-----	---	----	----	-----

名義期間 月 日	販売ポイント プッシュスタート バックモニター
輸入車	
ディーラー・並行	
左H・右H	

< 検査員記入欄 >

Fガラス (キズ・~~石~~・ヒビ・リペア済・X要)
 内装 (キズ・~~シミ~~・~~汚れ~~・シミ・コゲ・穴・キレ・破れ・割れ)
 オーディオ (無し・穴) / タイヤ (スタッドレス)

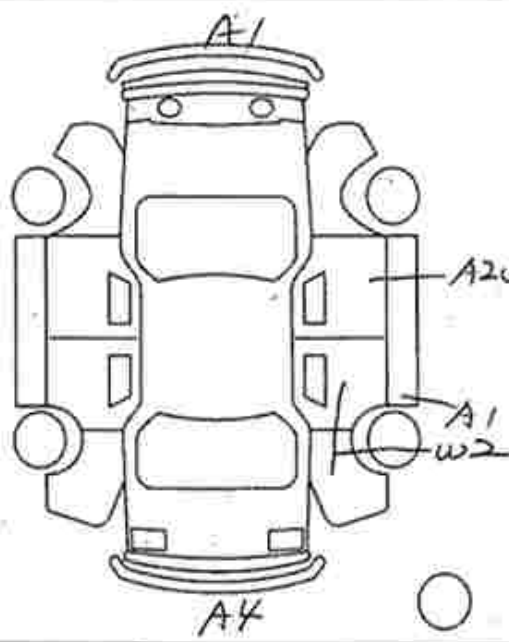

キーロック
 ホイル・CPキズワレノドアミラー(キズワレ)
 小キズ有 小キズ有 補修済

片ガラス気泡
152mm x 117mm
 ドア内装パネル
シートヘッドリ

後送 車	車種 ナンバー	ナビ設置 スペアキー	DM/SD キーレス	B-CAS スタートキー	リモコン	群馬 330 た 6826	車台番号 1014720
---------	------------	---------------	---------------	-----------------	------	---------------	-----------------











¹ Chassis number – a unique identification number of the vehicle in Japan (same as VIN in the USA or Europe)

² Title information:

Registered – qualified for driving in Japan

Deregistered Temporarily – not qualified for driving in Japan, usually a temporary title during the ownership change

Deregistered Completely – not qualified for driving in Japan, the vehicle is determined to be scrapped

Deregistered to Export – not qualified for driving in Japan, the vehicle is determined to be exported

³ Determining the overall collision safety performance evaluation – For the driver's seat, the results of the full-wrap frontal collision test, offset frontal collision test, and side collision test are added together and evaluated to 6 different levels. For the Frontal passenger's seat, the results of the full-wrap frontal collision test and the side collision test (results for the driver's or the front passenger's seat are used) are added together and evaluated to 6 different levels.

Regular vehicle inspection – All vehicles in Japan must undergo regular vehicle inspections (shaken). New cars need to be tested after three years, and then vehicles must be tested every two years thereafter. A vehicle inspection (shaken) is compulsory for all vehicles with an engine size over 250cc. It ensures that all vehicles on the road are properly maintained and safe to drive. The test also checks that vehicles have not been illegally modified; if they are found to have been modified, they are not allowed on the road.

⁴ Use in the contaminated regions – The Fukushima Daiichi nuclear disaster was a catastrophic failure at the Fukushima I Nuclear Power Plant on 11 March 2011, resulting in a meltdown of three of the plant's six nuclear reactors. As a result, some areas in the following prefectures were contaminated: Fukushima, Miyagi, Ibaraki, Tochigi.

⁵ Radioactive contamination test – radioactive contamination inspection that was started in July 2011 as a preventive measure for exporting contaminated vehicles from Japan. The inspection is being conducted since in all sea ports of Japan under the supervision of The Japan Harbor Transportation Association (JHTA).

MLIT – Ministry of Land, Infrastructure, Transport and Tourism.

⁶ Japan New Car Assessment Program – the Ministry of Land, Infrastructure, Transport and Tourism (MLIT) and the National Agency for Automotive Safety & Victims' Aid (NASVA) have taken measures for safety, one of which is to assess commercially available vehicles through a variety of safety performance tests and release the resulting information compiled into the "New Car Assessment Program". The objective of Japan New Car Assessment Program is to increase the use of safe automobiles by providing an environment in which users can easily select such vehicles. This also promotes the development of safer vehicles by automobile manufacturers. Neck injury protection for rear-end collision performance test, rear seat passenger's protection for frontal collision performance test, rear passenger's seat belt usability evaluation test and seat belt reminder for passengers evaluation test are started in FY2009.

⁷ Braking Performance Tests – Braking performance is determined by the shortness of the distance in which a vehicle can stop and the stability of the vehicle at the time of braking. This test is performed under wet and dry road conditions for a vehicle which has both a driver and a front passenger. The distance it takes for the vehicle to stop and the stability of the vehicle at the time of braking is evaluated for when the vehicle is stopped abruptly while traveling at a speed of 100km/h. The stopping distance and vehicle speed have been measured by using GPS since FY2009.

CAR VX, LTD DEPENDS ON ITS SOURCES FOR THE ACCURACY AND RELIABILITY OF ITS INFORMATION. THEREFORE, NO RESPONSIBILITY IS ASSUMED BY CAR VX, LTD OR ITS AGENTS FOR ERRORS OR OMISSIONS IN THIS REPORT. CAR VX, LTD FURTHER EXPRESSLY DISCLAIMS ALL WARRANTIES, EXPRESS OR IMPLIED, INCLUDING ANY IMPLIED WARRANTIES OF MERCHANTABILITY OR FITNESS FOR A PARTICULAR PURPOSE.

© 2014-2024 Car VX Limited. All rights reserved.