



# Vehicle History Report

## VEHICLE DETAILS

**Chassis number <sup>1</sup>:** GRS200-0010154

**Manufacture date:** 2008-05

**Make:** TOYOTA

**Model:** CROWN

**Body:** DBA-GRS200

**Grade:** ATHLETE NAVI PACKAGE

**Engine:** 4GR-FSE

**Drive:** 2WD

**Transmission:** AT

**Title information <sup>2</sup>:**



**Deregistered to Export**



**Accident / Repair:**



**No problem**



**Odometer rollback:**



**No problem**



**Manufacturer recall:**



**No problem**



**Safety grade <sup>3</sup>:**



**★★★★★**



**Contamination risk:**



**No problem**



**This vehicle does not qualify for Buyback Guarantee**

**Average Market Price**



Unfortunately, this vehicle does not qualify for our Buyback Guarantee program.



**¥0**

[About Buyback Guarantee](#)

This CAR VX Vehicle History Report is based only on Information supplied to CAR VX, LTD and available as of 2024-03-07 01:12:05. Other information about this vehicle, including problems, may not have been reported to CAR VX, LTD . Use this report as one important tool, along with a vehicle inspection and test drive, to make a better decision about your next used car.

## ACCIDENT / REPAIR HISTORY

Problem type	Reported	Date reported	Data source	Details	Airbag
Collision	Not reported				
Malfunction	Not reported				
Theft	Not reported				
Fire damage	Not reported				
Water damage	Not reported				
Hail damage	Not reported				

## ODOMETER READINGS HISTORY

Date reported	Data source	Odometer reading (Km)
2021-05-10	MLIT	60200
2023-04-24	MLIT	65900
2024-02-16	USS Nagoya	67316

## USE HISTORY

<b>Use in the contaminated regions <sup>4</sup></b>	<b>Radioactive contamination test fail <sup>5</sup></b>	<b>Commercial use</b>
Not reported	Not reported	Not reported

## DETAILED HISTORY

Event date	Location	Odometer reading (Km)	Data source	Details
2008-05			TOYOTA	Manufactured
2008-05			MLIT	First registration
2021-05-10		60200	MLIT	Inspection
2023-04-24	Yokohama	65900	MLIT	Inspection
2024-02-16	Aichi	67316	USS Nagoya	Auctioned

## MANUFACTURER RECALL HISTORY

Date reported	Data source	Affected part	Details
 Not reported			

## VEHICLE ASSESSMENT <sup>6</sup>

### Overall Collision Safety Ratings

Driver's seat			Front passenger's seat		
Points	Evaluation	Goal average	Points	Evaluation	Goal average
33.81	★★★★★	94%	22.5	★★★★★	94%

\* In order to accurately differentiate between the evaluations of different vehicles, a standard is set based on current technology. Up to 6 points out of 12 is given level 1 and the rest of the range is divided up into equal parts, which are respectively assigned to level 2 (more than 6 points but 7.5 or less), level 3 (more than 7.5 points but 9 or less), level 4 (more than 9 points but 10.5 or less) or level 5 (more than 10.5 points).

### Braking performance tests <sup>7</sup>

Dry road



44.4 m

Wet road



51.4 m

## VEHICLE SPECIFICATION

1st gear ratio	3.538	2nd gear ratio	2.060
3rd gear ratio	1.404	4th gear ratio	1.000
5th gear ratio	0.713	6th gear ratio	0.582
Additional notes	AETXH	Airbag position, capacity	-
Body rear overhang	1120	Body type	SEDAN

<b>Chassis number embossing position</b>	COWL TOP PANEL RIGHT SIDE	<b>Classification code</b>	0010
<b>Cylinders</b>	V6 LENGTHWAY	<b>Displacement</b>	2490
<b>Electric engine type</b>	-	<b>Electric engine maximum output</b>	-
<b>Electric engine maximum torque</b>	-	<b>Electric engine power</b>	-
<b>Engine maximum power</b>	158/6400( NET)	<b>Engine maximum torque</b>	260/3800( NET)
<b>Engine model</b>	4GR-FSE	<b>Frame type</b>	SOLID STRUCTURE
<b>Front shaft weight</b>	860	<b>Front shock absorber type</b>	
<b>Front stabilizer type</b>	TORSION BAR TYPE	<b>Front tires size</b>	225/45R18 91W
<b>Front tread</b>	1535	<b>Fuel consumption</b>	12.0
<b>Fuel tank equipment</b>	71	<b>Grade</b>	ATHLETE NAVI PACKAGE
<b>Height</b>	1470	<b>Length</b>	4870
<b>Main brakes type</b>	HYDRAULIC TYPE, DISK HYDRAULIC TYPE, DISK	<b>Make</b>	TOYOTA
<b>Maximum speed</b>	180	<b>Minimum ground clearance</b>	155
<b>Minimum turning radius</b>	5.2	<b>Model</b>	CROWN
<b>Model code</b>	DBA-GRS200	<b>Mufflers number</b>	
<b>Rear shaft weight</b>	750	<b>Rear shock absorber type</b>	
<b>Rear stabilizer type</b>	TORSION BAR TYPE	<b>Rear tires size</b>	225/45R18 91W
<b>Rear tread</b>	1535	<b>Reverse ratio</b>	3.168
<b>Riding capacity</b>	5	<b>Side brakes type</b>	MACHINE CAR WHEEL SHAPE( DRUM TYPE)
<b>Specification code</b>	16053	<b>Stopping distance</b>	49(100)
<b>Transmission type</b>	AT	<b>Weight</b>	1610
<b>Wheel alignment</b>	2WD	<b>Wheelbase</b>	2850
<b>Width</b>	1795		

## AUCTION DATA

Date: 2024-02-16, Auction: USS Nagoya, Lot #: 50296

Date:	2024-02-16	Lot #:	50296
Auction name:	<a href="#">USS Nagoya</a>	Region:	Aichi
Make:	TOYOTA	Model:	CROWN
Reg. year:	2008	Mileage (km):	67316
Displacement (cc):	2500	Transmission:	FA
Color:	SILVER	Model code:	GRS200
Result:	available	Auction grade:	4
Problem type:	No problem	Problem scale:	None
Contaminated:	No	Airbag:	OK

## PHOTOS AND AUCTION SHEETS

# プライム①コーナー

50296)	車種 (自動車以外は記入)	排気量	型式	4
	自家用	2570	DPA-6P220D	
	初年度登録年月	車名	グレード	2WD 4WD
	20/5月	7777	Trail-21 Trail	内装 B

車検	7年5月	シフト	FAT	SR	AW	ES	EW
走行	67316 Km	冷房	AAC	カワ	AV	EB	EW
外色	元色 シルバー 合體 - カラー 1P3	車検手数料 (国庫付)	有・無	ロールポイント *ユーザー買取車! *キリン! *11P-シート! *AW!			
内装	ガン①・緑油-( )	内装色					
輸入年月		輸入区分	ハンドル	月 日			
		ディーラー・旅行	左・右				

リサイクル 料金は 17080 円	車検定員	乗車定員	登録地	登録年	2006	登録月	5月
○注意事項 (検査・不具合箇所および状態等)			車台号	6P220-0010154			
			シリアル号				

## ○検査員報告 (USS使用済)

ル-2内 腐食なし  
 ホイルキス  
 ホイズ・ホイズ・サジキス  
 \_\_\_\_\_  
 \_\_\_\_\_  
 \_\_\_\_\_

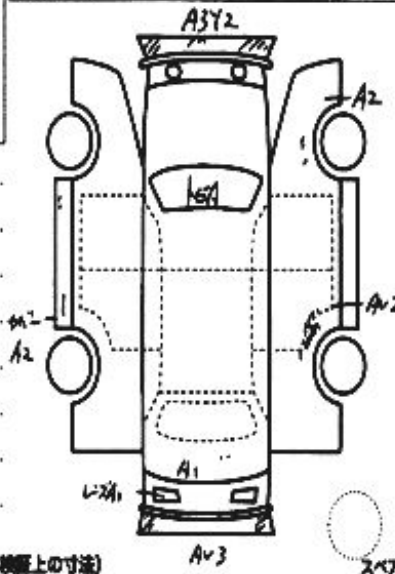

[荷台内寸] 約 X X (cm)

長さ cm 幅 cm 高さ cm ← (車検証上の寸法)

**<sup>1</sup> Chassis number** – a unique identification number of the vehicle in Japan (same as VIN in the USA or Europe)

**<sup>2</sup> Title information:**

Registered – qualified for driving in Japan

Deregistered Temporarily – not qualified for driving in Japan, usually a temporary title during the ownership change

Deregistered Completely – not qualified for driving in Japan, the vehicle is determined to be scrapped

Deregistered to Export – not qualified for driving in Japan, the vehicle is determined to be exported

**<sup>3</sup> Determining the overall collision safety performance evaluation** – For the driver's seat, the results of the full-wrap frontal collision test, offset frontal collision test, and side collision test are added together and evaluated to 6 different levels. For the Frontal passenger's seat, the results of the full-wrap frontal collision test and the side collision test (results for the driver's or the front passenger's seat are used) are added together and evaluated to 6 different levels.

Regular vehicle inspection – All vehicles in Japan must undergo regular vehicle inspections (shaken). New cars need to be tested after three years, and then vehicles must be tested every two years thereafter. A vehicle inspection (shaken) is compulsory for all vehicles with an engine size over 250cc. It ensures that all vehicles on the road are properly maintained and safe to drive. The test also checks that vehicles have not been illegally modified; if they are found to have been modified, they are not allowed on the road.

**<sup>4</sup> Use in the contaminated regions** – The Fukushima Daiichi nuclear disaster was a catastrophic failure at the Fukushima I Nuclear Power Plant on 11 March 2011, resulting in a meltdown of three of the plant's six nuclear reactors. As a result, some areas in the following prefectures were contaminated: Fukushima, Miyagi, Ibaraki, Tochigi.

**<sup>5</sup> Radioactive contamination test** – radioactive contamination inspection that was started in July 2011 as a preventive measure for exporting contaminated vehicles from Japan. The inspection is being conducted since in all sea ports of Japan under the supervision of The Japan Harbor Transportation Association (JHTA).

MLIT – Ministry of Land, Infrastructure, Transport and Tourism.

**<sup>6</sup> Japan New Car Assessment Program** – the Ministry of Land, Infrastructure, Transport and Tourism (MLIT) and the National Agency for Automotive Safety & Victims' Aid (NASVA) have taken measures for safety, one of which is to assess commercially available vehicles through a variety of safety performance tests and release the resulting information compiled into the "New Car Assessment Program". The objective of Japan New Car Assessment Program is to increase the use of safe automobiles by providing an environment in which users can easily select such vehicles. This also promotes the development of safer vehicles by automobile manufacturers. Neck injury protection for rear-end collision performance test, rear seat passenger's protection for frontal collision performance test, rear passenger's seat belt usability evaluation test and seat belt reminder for passengers evaluation test are started in FY2009.

**<sup>7</sup> Braking Performance Tests** – Braking performance is determined by the shortness of the distance in which a vehicle can stop and the stability of the vehicle at the time of braking. This test is performed under wet and dry road conditions for a vehicle which has both a driver and a front passenger. The distance it takes for the vehicle to stop and the stability of the vehicle at the time of braking is evaluated for when the vehicle is stopped abruptly while traveling at a speed of 100km/h. The stopping distance and vehicle speed have been measured by using GPS since FY2009.

CAR VX, LTD DEPENDS ON ITS SOURCES FOR THE ACCURACY AND RELIABILITY OF ITS INFORMATION. THEREFORE, NO RESPONSIBILITY IS ASSUMED BY CAR VX, LTD OR ITS AGENTS FOR ERRORS OR OMISSIONS IN THIS REPORT. CAR VX, LTD FURTHER EXPRESSLY DISCLAIMS ALL WARRANTIES, EXPRESS OR IMPLIED, INCLUDING ANY IMPLIED WARRANTIES OF MERCHANTABILITY OR FITNESS FOR A PARTICULAR PURPOSE.

© 2014-2024 Car VX Limited. All rights reserved.