



Vehicle History Report

VEHICLE DETAILS

Chassis number ¹: TE52-029744

Manufacture date: 2012-02

Make: NISSAN

Model: ELGRAND

Body: DBA-TE52

Grade: 250 HIGHWAY STAR URBAN CHROME

Engine: QR25DE

Drive: 2WD

Transmission: AT

Title information ²:



Deregistered to Export



Accident / Repair:



No problem



Odometer rollback:



No problem



Manufacturer recall:



No problem



Safety grade ³:



★★★★★



Contamination risk:



No problem



This CAR VX Vehicle History Report is based only on Information supplied to CAR VX, LTD and available as of 2026-03-13 09:48:12. Other information about this vehicle, including problems, may not have been reported to CAR VX, LTD . Use this report as one important tool, along with a vehicle inspection and test drive, to make a better decision about your next used car.

ACCIDENT / REPAIR HISTORY

Problem type	Reported	Date reported	Data source	Details	Airbag
Collision	Not reported				
Malfunction	Not reported				
Theft	Not reported				
Fire damage	Not reported				
Water damage	Not reported				
Hail damage	Not reported				

ODOMETER READINGS HISTORY

Date reported	Data source	Odometer reading (Km)
2023-02-01	MLIT	69800
2025-01-28	MLIT	81000
2026-02-26	USS Tokyo	82841

USE HISTORY

Use in the contaminated regions ⁴	Radioactive contamination test fail ⁵	Commercial use
Not reported	Not reported	Not reported

DETAILED HISTORY

Event date	Location	Odometer reading (Km)	Data source	Details
2012-02			NISSAN	Manufactured
2012-02			MLIT	First registration
2023-02-01		69800	MLIT	Inspection
2025-01-28	Fukuoka	81000	MLIT	Inspection
2026-02-26	Chiba	82841	USS Tokyo	Auctioned

MANUFACTURER RECALL HISTORY

Date reported	Data source	Affected part	Details
---------------	-------------	---------------	---------

 Not reported

VEHICLE ASSESSMENT ⁶

Overall Collision Safety Ratings

Driver's seat			Front passenger's seat		
Points	Evaluation	Goal average	Points	Evaluation	Goal average
35.37	★★★★★	98%	23.33	★★★★★	97%

* In order to accurately differentiate between the evaluations of different vehicles, a standard is set based on current technology. Up to 6 points out of 12 is given level 1 and the rest of the range is divided up into equal parts, which are respectively assigned to level 2 (more than 6 points but 7.5 or less), level 3 (more than 7.5 points but 9 or less), level 4 (more than 9 points but 10.5 or less) or level 5 (more than 10.5 points).

Braking performance tests ⁷

Dry road



40.5 m

Wet road



43.4 m

VEHICLE SPECIFICATION

1st gear ratio

2.349 ~ 0.394(MANUAL
MODE ATTACHING)

2nd gear ratio

-

3rd gear ratio

-

4th gear ratio

-

5th gear ratio

-

6th gear ratio

-

Additional notes

-

Airbag position,
capacity

Body rear overhang

1020

Body type

MV&1BOX

Chassis number embossing position		Classification code	0042
Cylinders	4	Displacement	2480
Electric engine type	-	Electric engine maximum output	-
Electric engine maximum torque	-	Electric engine power	-
Engine maximum power	125/5600(NET)	Engine maximum torque	245/3900(NET)
Engine model	QR25DE	Frame type	SOLID STRUCTURE
Front shaft weight	1040	Front shock absorber type	
Front stabilizer type	TORSION BAR TYPE	Front tires size	225/55R18 98V
Front tread	1.600	Fuel consumption	11.6
Fuel tank equipment	73	Grade	250 HIGHWAY STAR URBAN CHROME
Height	1.815	Length	4.945
Main brakes type		Make	NISSAN
Maximum speed	180	Minimum ground clearance	0.150
Minimum turning radius	5.7	Model	ELGRAND
Model code	DBA-TE52	Mufflers number	
Rear shaft weight	900	Rear shock absorber type	
Rear stabilizer type	TORSION BAR TYPE -	Rear tires size	225/55R18 98V
Rear tread	1.600	Reverse ratio	1.750
Riding capacity	7	Side brakes type	
Specification code	16576	Stopping distance	50(100)
Transmission type	AT	Weight	1940
Wheel alignment	2WD	Wheelbase	3.000
Width	1.850		

Date: 2026-02-26, Auction: USS Tokyo, Lot #: 26056

Date:	2026-02-26	Lot #:	26056
Auction name:	USS Tokyo	Region:	Chiba
Make:	NISSAN	Model:	ELGRAND
Reg. year:	2012	Mileage (km):	82841
Displacement (cc):	2500	Transmission:	IA
Color:	PEARL	Model code:	TE52
Result:	available	Auction grade:	4
Problem type:	No problem	Problem scale:	None
Contaminated:	No	Airbag:	OK

PHOTOS AND AUCTION SHEETS

プライムコーナー

26056	車種 (車検用以外は記入)	排気量	型式	4
		2500	DBA-TE52	
	初年度登録年月 H24/2月	車名 エルブランド	グレード 250ハイウェイ ターアーバンクром	2WD

車検 R9年 2月 22日	シフト IAT	特注品
走行 82,841 km	冷房 AAC	SR (有) PS (有) PV (有)
外色 パール	カラー名 QAB	カワ TV ナビ EAP
燃料 ガソリン	有	セールスポイント
リサイクル	月 日	★インテリジェントキー×2
リサイクル料 16,190円		★アラウンドビューモニター
乗車定員 7人		★ハーフレザーシート
		★両側パワースライドドア
		★ビルトインETC

登録地 千葉	登録年 335	ね 1881
車台号 TE52-029744		
シリアル号		

★H24からR8まで毎年全ディーラー記録簿

○検査員報告

ルーム内汚れ、スレ
ダッシュ板フレ
ホイールキズ
各キズ凹

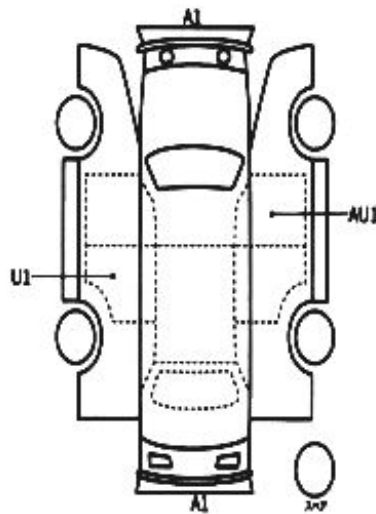

【荷台内寸】約	x	x	(cm)
長さ 494 cm	幅 185 cm	高さ 181 cm	

¹ Chassis number – a unique identification number of the vehicle in Japan (same as VIN in the USA or Europe)

² Title information:

Registered – qualified for driving in Japan

Deregistered Temporarily – not qualified for driving in Japan, usually a temporary title during the ownership change

Deregistered Completely – not qualified for driving in Japan, the vehicle is determined to be scrapped

Deregistered to Export – not qualified for driving in Japan, the vehicle is determined to be exported

³ Determining the overall collision safety performance evaluation – For the driver's seat, the results of the full-wrap frontal collision test, offset frontal collision test, and side collision test are added together and evaluated to 6 different levels. For the Frontal passenger's seat, the results of the full-wrap frontal collision test and the side collision test (results for the driver's or the front passenger's seat are used) are added together and evaluated to 6 different levels.

Regular vehicle inspection – All vehicles in Japan must undergo regular vehicle inspections (shaken). New cars need to be tested after three years, and then vehicles must be tested every two years thereafter. A vehicle inspection (shaken) is compulsory for all vehicles with an engine size over 250cc. It ensures that all vehicles on the road are properly maintained and safe to drive. The test also checks that vehicles have not been illegally modified; if they are found to have been modified, they are not allowed on the road.

⁴ Use in the contaminated regions – The Fukushima Daiichi nuclear disaster was a catastrophic failure at the Fukushima I Nuclear Power Plant on 11 March 2011, resulting in a meltdown of three of the plant's six nuclear reactors. As a result, some areas in the following prefectures were contaminated: Fukushima, Miyagi, Ibaraki, Tochigi.

⁵ Radioactive contamination test – radioactive contamination inspection that was started in July 2011 as a preventive measure for exporting contaminated vehicles from Japan. The inspection is being conducted since in all sea ports of Japan under the supervision of The Japan Harbor Transportation Association (JHTA).

MLIT – Ministry of Land, Infrastructure, Transport and Tourism.

⁶ Japan New Car Assessment Program – the Ministry of Land, Infrastructure, Transport and Tourism (MLIT) and the National Agency for Automotive Safety & Victims' Aid (NASVA) have taken measures for safety, one of which is to assess commercially available vehicles through a variety of safety performance tests and release the resulting information compiled into the "New Car Assessment Program". The objective of Japan New Car Assessment Program is to increase the use of safe automobiles by providing an environment in which users can easily select such vehicles. This also promotes the development of safer vehicles by automobile manufacturers. Neck injury protection for rear-end collision performance test, rear seat passenger's protection for frontal collision performance test, rear passenger's seat belt usability evaluation test and seat belt reminder for passengers evaluation test are started in FY2009.

⁷ Braking Performance Tests – Braking performance is determined by the shortness of the distance in which a vehicle can stop and the stability of the vehicle at the time of braking. This test is performed under wet and dry road conditions for a vehicle which has both a driver and a front passenger. The distance it takes for the vehicle to stop and the stability of the vehicle at the time of braking is evaluated for when the vehicle is stopped abruptly while traveling at a speed of 100km/h. The stopping distance and vehicle speed have been measured by using GPS since FY2009.

CAR VX, LTD DEPENDS ON ITS SOURCES FOR THE ACCURACY AND RELIABILITY OF ITS INFORMATION. THEREFORE, NO RESPONSIBILITY IS ASSUMED BY CAR VX, LTD OR ITS AGENTS FOR ERRORS OR OMISSIONS IN THIS REPORT. CAR VX, LTD FURTHER EXPRESSLY DISCLAIMS ALL WARRANTIES, EXPRESSED OR IMPLIED, INCLUDING ANY IMPLIED WARRANTIES OF MERCHANTABILITY OR FITNESS FOR A PARTICULAR PURPOSE.

© 2014-2026 Car VX Limited. All rights reserved.