



# Vehicle History Report

## VEHICLE DETAILS

**Chassis number <sup>1</sup>:** ZRR80-0006421

**Manufacture date:** 2014-01

**Make:** TOYOTA

**Model:** NOAH

**Body:** DBA-ZRR80G

**Grade:** X

**Engine:** 3ZR-FAE

**Drive:** 2WD

**Transmission:** AT

**Title information <sup>2</sup>:**  **Registered** 

**Accident / Repair:**  **No problem** 

**Odometer rollback:**  **No problem** 

**Manufacturer recall:**  **No problem** 

**Safety grade <sup>3</sup>:**  **★★★★★** 

**Contamination risk:**  **Problem found** 

This CAR VX Vehicle History Report is based only on Information supplied to CAR VX, LTD and available as of 2026-04-11 07:38:01. Other information about this vehicle, including problems, may not have been reported to CAR VX, LTD . Use this report as one important tool, along with a vehicle inspection and test drive, to make a better decision about your next used car.

## ACCIDENT / REPAIR HISTORY

Problem type	Reported	Date reported	Data source	Details	Airbag
Collision	Not reported				
Malfunction	Not reported				
Theft	Not reported				
Fire damage	Not reported				
Water damage	Not reported				
Hail damage	Not reported				

## ODOMETER READINGS HISTORY

Date reported	Data source	Odometer reading (Km)
2023-02-07	MLIT	87100
2025-02-07	MLIT	108600
2026-03-01	Kyouyuu Stock	119000
2026-03-31	CAA Tokyo	119492

## USE HISTORY

<b>Use in the contaminated regions</b> <sup>4</sup>	<b>Radioactive contamination test fail</b> <sup>5</sup>	<b>Commercial use</b>
Reported	Not reported	Not reported

## DETAILED HISTORY

Event date	Location	Odometer reading (Km)	Data source	Details
2014-01			TOYOTA	Manufactured
2014-02			MLIT	First registration
2023-02-07		87100	MLIT	Inspection
2025-02-07	Tsuchiura	108600	MLIT	Inspection

2026-02-16	Tsuchiura		MLIT	Last registration
2026-03-01		119000	Kyouyuu Stock	Auctioned
2026-03-31	Chiba	119492	CAA Tokyo	Auctioned

## MANUFACTURER RECALL HISTORY

Date reported	Data source	Affected part	Details
---------------	-------------	---------------	---------

 Not reported



## VEHICLE ASSESSMENT <sup>6</sup>

### Overall Collision Safety Ratings

Driver's seat			Front passenger's seat		
Points	Evaluation	Goal average	Points	Evaluation	Goal average
11.18	★★★★★	93%	9.8	★★★★	82%

\* In order to accurately differentiate between the evaluations of different vehicles, a standard is set based on current technology. Up to 6 points out of 12 is given level 1 and the rest of the range is divided up into equal parts, which are respectively assigned to level 2 (more than 6 points but 7.5 or less), level 3 (more than 7.5 points but 9 or less), level 4 (more than 9 points but 10.5 or less) or level 5 (more than 10.5 points).

### Braking performance tests <sup>7</sup>

Dry road		41.8 m
Wet road		44.6 m

## VEHICLE SPECIFICATION

1st gear ratio

2nd gear ratio

3rd gear ratio

4th gear ratio

5th gear ratio

6th gear ratio

Additional notes

Airbag position,  
capacity

<b>Body rear overhang</b>		<b>Body type</b>	MV&1BOX
<b>Chassis number embossing position</b>		<b>Classification code</b>	4
<b>Cylinders</b>	4	<b>Displacement</b>	1980
<b>Electric engine type</b>		<b>Electric engine maximum output</b>	
<b>Electric engine maximum torque</b>		<b>Electric engine power</b>	
<b>Engine maximum power</b>	152ps(112kW)/6100rpm	<b>Engine maximum torque</b>	19.7kg·m(193N·m)/3800rpm
<b>Engine model</b>	3ZR-FAE	<b>Frame type</b>	
<b>Front shaft weight</b>	910	<b>Front shock absorber type</b>	
<b>Front stabilizer type</b>		<b>Front tires size</b>	195/65R15
<b>Front tread</b>	1480	<b>Fuel consumption</b>	
<b>Fuel tank equipment</b>	55	<b>Grade</b>	X
<b>Height</b>	182	<b>Length</b>	469
<b>Main brakes type</b>		<b>Make</b>	TOYOTA
<b>Maximum speed</b>		<b>Minimum ground clearance</b>	
<b>Minimum turning radius</b>	5.5	<b>Model</b>	NOAH
<b>Model code</b>	DBA-ZRR80G	<b>Mufflers number</b>	
<b>Rear shaft weight</b>	660	<b>Rear shock absorber type</b>	
<b>Rear stabilizer type</b>		<b>Rear tires size</b>	195/65R15
<b>Rear tread</b>	1475	<b>Reverse ratio</b>	
<b>Riding capacity</b>	7	<b>Side brakes type</b>	
<b>Specification code</b>	17697	<b>Stopping distance</b>	
<b>Transmission type</b>	AT	<b>Weight</b>	1570
<b>Wheel alignment</b>	2WD	<b>Wheelbase</b>	2850
<b>Width</b>	169		

**Date: 2026-03-01, Auction: Kyouyuu Stock, Lot #: 87131**

Date:	2026-03-01	Lot #:	87131
Auction name:	Kyouyuu Stock	Region:	
Make:	TOYOTA	Model:	NOAH
Reg. year:	2014	Mileage (km):	119000
Displacement (cc):	2000	Transmission:	IAT
Color:	LIGHT BROWN	Model code:	ZRR80G
Result:	available	Auction grade:	
Problem type:	No problem	Problem scale:	None
Contaminated:	No	Airbag:	OK

**Date: 2026-03-31, Auction: CAA Tokyo, Lot #: 31106**

Date:	2026-03-31	Lot #:	31106
Auction name:	<a href="#">CAA Tokyo</a>	Region:	Chiba
Make:	TOYOTA	Model:	NOAH
Reg. year:	2014	Mileage (km):	119492
Displacement (cc):	2000	Transmission:	IAT
Color:	BROWN	Model code:	ZRR80G
Result:	sold	Auction grade:	4
Problem type:	No problem	Problem scale:	None
Contaminated:	No	Airbag:	OK

**PHOTOS AND AUCTION SHEETS**

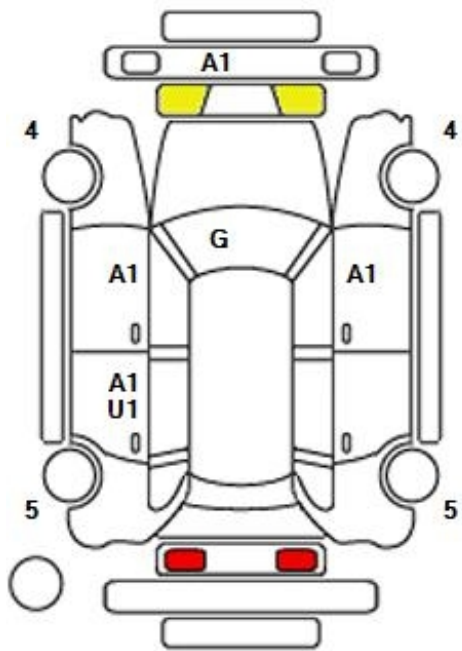

**N** ネクステージ



出品番号	初度登録	車名	ドア形状	グレード	評価点
31106 初出品	H26	ノア	5W	X	4
	年	車歴	排気量	燃料	型式
	2月	自家用	2000cc	ガソリン	DBA-ZRR80G
					外装 内装
					B B

走行	車検	登録番号	譲渡書類期限	セールスポイント	
119,492 km	09年02月	つくば 501f7057	月 日	★ユーザー買取車★バックカメラ、★パワースライドドア★ETC	
シフト	エアコン	外装色	乗車定員	最大積載量	
IAT	WAC	ブラウン	7人	kg	
		カラーNo.	内装色	輸入車	リサイクル預託金
		4W4	系		13,600円
後日発送部品				純正装備	
				北 TV I7B PS PW	

注意事項欄			車台番号		
			ZRR80-0006421		
			諸元		
長さ 469		幅 169	高さ 182		

検査員記入欄
室内薄汚れ ホイールカバーA 外装小傷有り
事務局よりご案内
SDケース

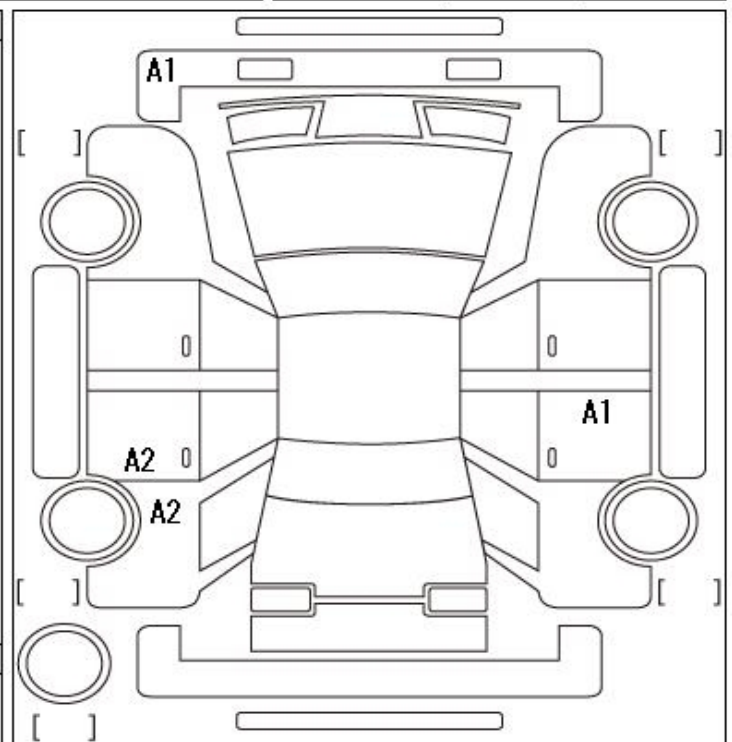

A:軽 U:43 B:軽を伴う43 P:要塗装 W:補修済 S:錆 C:腐食、穴 G:加付点検 XX:交換済み X:要交換 欠:欠品 内・外装評価 5段階5段階(A・B・C・D・E) 2







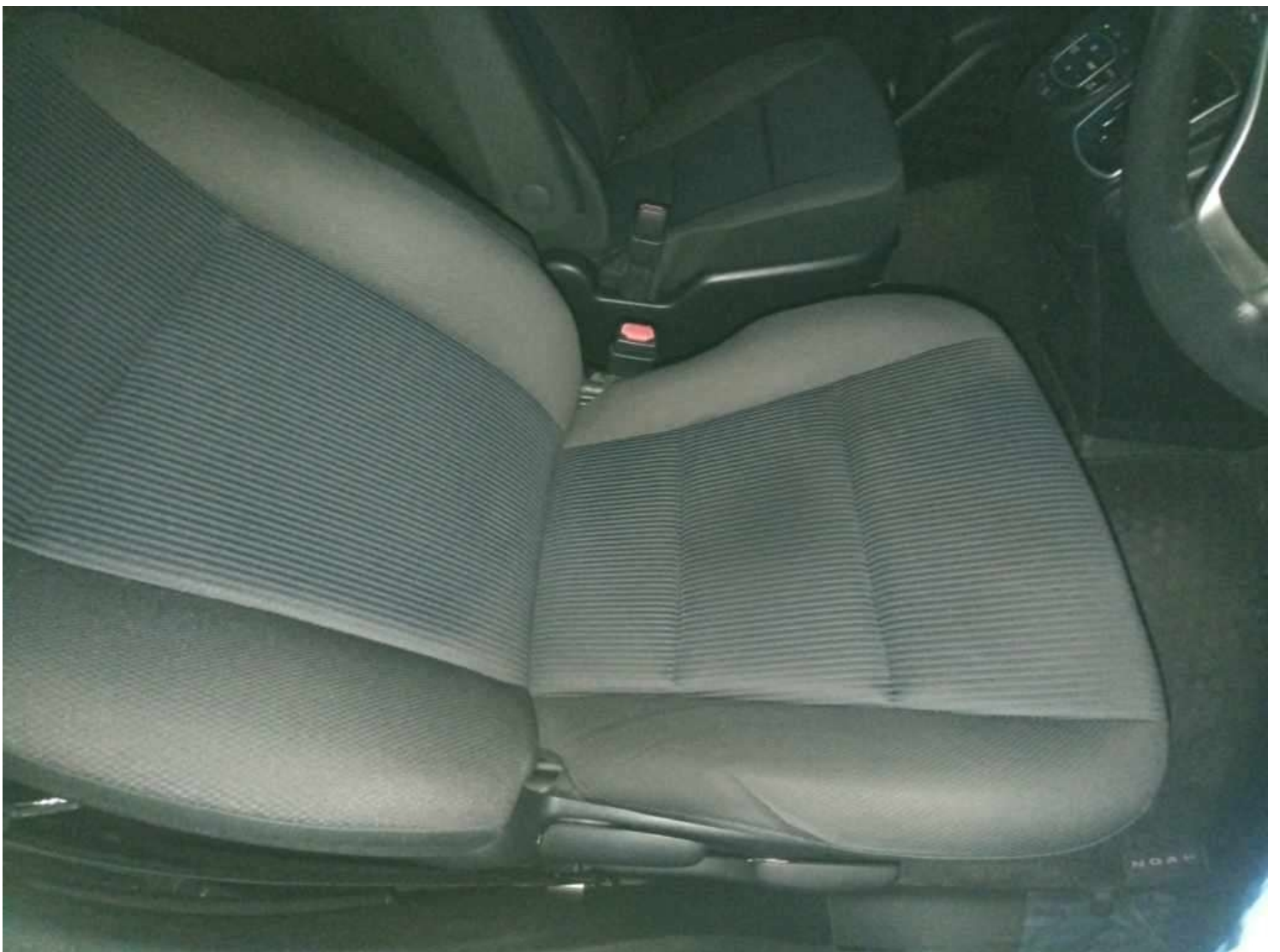







**<sup>1</sup> Chassis number** – a unique identification number of the vehicle in Japan (same as VIN in the USA or Europe)

**<sup>2</sup> Title information:**

Registered – qualified for driving in Japan

Deregistered Temporarily – not qualified for driving in Japan, usually a temporary title during the ownership change

Deregistered Completely – not qualified for driving in Japan, the vehicle is determined to be scrapped

Deregistered to Export – not qualified for driving in Japan, the vehicle is determined to be exported

**<sup>3</sup> Determining the overall collision safety performance evaluation** – For the driver's seat, the results of the full-wrap frontal collision test, offset frontal collision test, and side collision test are added together and evaluated to 6 different levels. For the Frontal passenger's seat, the results of the full-wrap frontal collision test and the side collision test (results for the driver's or the front passenger's seat are used) are added together and evaluated to 6 different levels.

Regular vehicle inspection – All vehicles in Japan must undergo regular vehicle inspections (shaken). New cars need to be tested after three years, and then vehicles must be tested every two years thereafter. A vehicle inspection (shaken) is compulsory for all vehicles with an engine size over 250cc. It ensures that all vehicles on the road are properly maintained and safe to drive. The test also checks that vehicles have not been illegally modified; if they are found to have been modified, they are not allowed on the road.

**<sup>4</sup> Use in the contaminated regions** – The Fukushima Daiichi nuclear disaster was a catastrophic failure at the Fukushima I Nuclear Power Plant on 11 March 2011, resulting in a meltdown of three of the plant's six nuclear reactors. As a result, some areas in the following prefectures were contaminated: Fukushima, Miyagi, Ibaraki, Tochigi.

**<sup>5</sup> Radioactive contamination test** – radioactive contamination inspection that was started in July 2011 as a preventive measure for exporting contaminated vehicles from Japan. The inspection is being conducted since in all sea ports of Japan under the supervision of The Japan Harbor Transportation Association (JHTA).

MLIT – Ministry of Land, Infrastructure, Transport and Tourism.

**<sup>6</sup> Japan New Car Assessment Program** – the Ministry of Land, Infrastructure, Transport and Tourism (MLIT) and the National Agency for Automotive Safety & Victims' Aid (NASVA) have taken measures for safety, one of which is to assess commercially available vehicles through a variety of safety performance tests and release the resulting information compiled into the "New Car Assessment Program". The objective of Japan New Car Assessment Program is to increase the use of safe automobiles by providing an environment in which users can easily select such vehicles. This also promotes the development of safer vehicles by automobile manufacturers. Neck injury protection for rear-end collision performance test, rear seat passenger's protection for frontal collision performance test, rear passenger's seat belt usability evaluation test and seat belt reminder for passengers evaluation test are started in FY2009.

**<sup>7</sup> Braking Performance Tests** – Braking performance is determined by the shortness of the distance in which a vehicle can stop and the stability of the vehicle at the time of braking. This test is performed under wet and dry road conditions for a vehicle which has both a driver and a front passenger. The distance it takes for the vehicle to stop and the stability of the vehicle at the time of braking is evaluated for when the vehicle is stopped abruptly while traveling at a speed of 100km/h. The stopping distance and vehicle speed have been measured by using GPS since FY2009.

CAR VX, LTD DEPENDS ON ITS SOURCES FOR THE ACCURACY AND RELIABILITY OF ITS INFORMATION. THEREFORE, NO RESPONSIBILITY IS ASSUMED BY CAR VX, LTD OR ITS AGENTS FOR ERRORS OR OMISSIONS IN THIS REPORT. CAR VX, LTD FURTHER EXPRESSLY DISCLAIMS ALL WARRANTIES, EXPRESSED OR IMPLIED, INCLUDING ANY IMPLIED WARRANTIES OF MERCHANTABILITY OR FITNESS FOR A PARTICULAR PURPOSE.

© 2014-2026 Car VX Limited. All rights reserved.