



Vehicle History Report

VEHICLE DETAILS

Chassis number ¹: ANH20-8286266

Manufacture date: 2013

Make: TOYOTA

Model: VELLFIRE

Body: DBA-ANH20W

Grade: 2.4Z

Engine: 2AZ-FE

Drive: 2WD

Transmission: AT

Title information ²:



Deregistered to Export



Accident / Repair:



No problem



Odometer rollback:



No problem



Manufacturer recall:



No problem



Safety grade ³:



★★★★★★



Contamination risk:



No problem



This CAR VX Vehicle History Report is based only on Information supplied to CAR VX, LTD and available as of 2026-05-31 21:09:27. Other information about this vehicle, including problems, may not have been reported to CAR VX, LTD . Use this report as one important tool, along with a vehicle inspection and test drive, to make a better decision about your next used car.

ACCIDENT / REPAIR HISTORY

Problem type	Reported	Date reported	Data source	Details	Airbag
Collision	Not reported				
Malfunction	Not reported				
Theft	Not reported				
Fire damage	Not reported				
Water damage	Not reported				
Hail damage	Not reported				

ODOMETER READINGS HISTORY

Date reported	Data source	Odometer reading (Km)
2022-06-07	MLIT	88100
2024-06-21	MLIT	109200
2026-05-14	NAA Nagoya	128803

USE HISTORY

Use in the contaminated regions ⁴	Radioactive contamination test fail ⁵	Commercial use
Not reported	Not reported	Not reported

DETAILED HISTORY

Event date	Location	Odometer reading (Km)	Data source	Details
2013			TOYOTA	Manufactured
2013-07			MLIT	First registration
2022-06-07		88100	MLIT	Inspection
2024-06-21	Nagoya	109200	MLIT	Inspection
2026-04-24	Nagoya		MLIT	Last registration

MANUFACTURER RECALL HISTORY

Date reported	Data source	Affected part	Details
 Not reported			

VEHICLE ASSESSMENT ⁶

Overall Collision Safety Ratings

Driver's seat			Front passenger's seat		
Points	Evaluation	Goal average	Points	Evaluation	Goal average
34.46	★★★★★★	96%	23.51	★★★★★★	98%

* In order to accurately differentiate between the evaluations of different vehicles, a standard is set based on current technology. Up to 6 points out of 12 is given level 1 and the rest of the range is divided up into equal parts, which are respectively assigned to level 2 (more than 6 points but 7.5 or less), level 3 (more than 7.5 points but 9 or less), level 4 (more than 9 points but 10.5 or less) or level 5 (more than 10.5 points).

Braking performance tests ⁷

Dry road



41.7 m

Wet road



47.1 m

VEHICLE SPECIFICATION

1st gear ratio	2.396 ~ 0.428(MANUAL MODE ATTACHING): CONTINUOUSLY VARIABLE TRANSMISSION	2nd gear ratio	-
3rd gear ratio	-	4th gear ratio	-
5th gear ratio	-	6th gear ratio	-
Additional notes	NFXSK	Airbag position, capacity	
Body rear overhang	1015	Body type	MV&1BOX

Chassis number embossing position	FRONT FLOOR CROSSMEMBER RIGHT SIDE ON SURFACE	Classification code	0465
Cylinders		Displacement	2360
Electric engine type	-	Electric engine maximum output	-
Electric engine maximum torque	-	Electric engine power	-
Engine maximum power	125/6000(NET)	Engine maximum torque	224/4000(NET)
Engine model	2AZ-FE	Frame type	SOLID STRUCTURE
Front shaft weight	1050	Front shock absorber type	
Front stabilizer type	TORSION BAR TYPE	Front tires size	215/60R17 96H 235/50R18 97V
Front tread	1.580	Fuel consumption	-
Fuel tank equipment	65	Grade	2.4Z
Height	1.900	Length	4.885
Main brakes type	HYDRAULIC TYPE, FRONT: DISK BACK: DISK	Make	TOYOTA
Maximum speed	180	Minimum ground clearance	0.160 0.170
Minimum turning radius	5.9	Model	VELLFIRE
Model code	DBA-ANH20W	Mufflers number	
Rear shaft weight	840	Rear shock absorber type	
Rear stabilizer type	-	Rear tires size	215/60R17 96H 235/50R18 98V
Rear tread	1.585	Reverse ratio	1.668
Riding capacity	7	Side brakes type	

Specification code	16086	Stopping distance	50(100)
Transmission type	AT	Weight	1890
Wheel alignment	2WD	Wheelbase	2.950
Width	1.840		

AUCTION DATA

Date: 2026-05-14, Auction: NAA Nagoya, Lot #: 4181

Date:	2026-05-14	Lot #:	4181
Auction name:	NAA Nagoya	Region:	Aichi
Make:	TOYOTA	Model:	VELLFIRE
Reg. year:	2013	Mileage (km):	128803
Displacement (cc):	2400	Transmission:	IAT
Color:	PEARL WHITE	Model code:	ANH20W
Result:	sold	Auction grade:	4
Problem type:	No problem	Problem scale:	None
Contaminated:	No	Airbag:	OK

PHOTOS AND AUCTION SHEETS

初年登録 H25 07	年 月	車名 ウエルファイ ドライブ 5 B7コン	燃料 G	排気量 2400 cc	グレード 2.4Z
シフト IAT	外装色 パールホワイト	色番	内装色	系	走行 128,803 km
車歴	外形態 ハンドル	書類期限 月 日 検	車年 月	型式 DBA-ANH20W ANH20-8286266	基本型式 車台No.
乗車定員 7 人乗	整備手帳 新車保証書 ステッカー	無	リサイクル料預託額 預託16,260	冷房 AAC	ナビ セン ASTア 地デジ Bモニタ インテリ PS PW 17B ABS

* 特記事項 *

純正後付ナビ MZN-X62GH

総合評価	外装評価	内装評価
4.0	B	B

* 検査員報告備考 *

スマートキー、ディスプレイヘッド
外ゲリル
外装小キズあり
Fバンパー下キズ

* 会場コメント *

* セールスポイント *

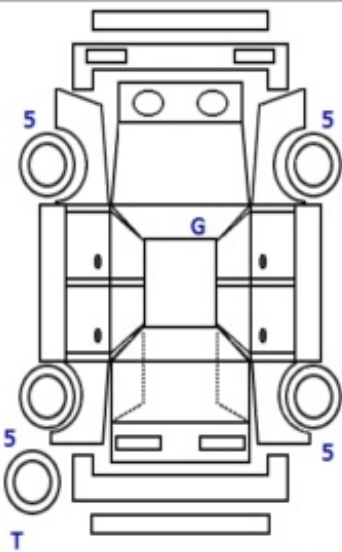

Aキズ U凹 B傷凹 P要塗装 W補修跡 Sサビ C腐食 G飛石傷 X要交換 XX交換 タイヤの残溝はmm表示です







1 Chassis number – a unique identification number of the vehicle in Japan (same as VIN in the USA or Europe)

2 Title information:

Registered – qualified for driving in Japan

Deregistered Temporarily – not qualified for driving in Japan, usually a temporary title during the ownership change

Deregistered Completely – not qualified for driving in Japan, the vehicle is determined to be scrapped

Deregistered to Export – not qualified for driving in Japan, the vehicle is determined to be exported

3 Determining the overall collision safety performance evaluation – For the driver's seat, the results of the full-wrap frontal collision test, offset frontal collision test, and side collision test are added together and evaluated to 6 different levels. For the Frontal passenger's seat, the results of the full-wrap frontal collision test and the side collision test (results for the driver's or the front passenger's seat are used) are added together and evaluated to 6 different levels.

Regular vehicle inspection – All vehicles in Japan must undergo regular vehicle inspections (shaken). New cars need to be tested after three years, and then vehicles must be tested every two years thereafter. A vehicle inspection (shaken) is compulsory for all vehicles with an engine size over 250cc. It ensures that all vehicles on the road are properly maintained and safe to drive. The test also checks that vehicles have not been illegally modified; if they are found to have been modified, they are not allowed on the road.

4 Use in the contaminated regions – The Fukushima Daiichi nuclear disaster was a catastrophic failure at the Fukushima I Nuclear Power Plant on 11 March 2011, resulting in a meltdown of three of the plant's six nuclear reactors. As a result, some areas in the following prefectures were contaminated: Fukushima, Miyagi, Ibaraki, Tochigi.

5 Radioactive contamination test – radioactive contamination inspection that was started in July 2011 as a preventive measure for exporting contaminated vehicles from Japan. The inspection is being conducted since in all sea ports of Japan under the supervision of The Japan Harbor Transportation Association (JHTA).

MLIT – Ministry of Land, Infrastructure, Transport and Tourism.

6 Japan New Car Assessment Program – the Ministry of Land, Infrastructure, Transport and Tourism (MLIT) and the National Agency for Automotive Safety & Victims' Aid (NASVA) have taken measures for safety, one of which is to assess commercially available vehicles through a variety of safety performance tests and release the resulting information compiled into the "New Car Assessment Program". The objective of Japan New Car Assessment Program is to increase the use of safe automobiles by providing an environment in which users can easily select such vehicles. This also promotes the development of safer vehicles by automobile manufacturers. Neck injury protection for rear-end collision performance test, rear seat passenger's protection for frontal collision performance test, rear passenger's seat belt usability evaluation test and seat belt reminder for passengers evaluation test are started in FY2009.

7 Braking Performance Tests – Braking performance is determined by the shortness of the distance in which a vehicle can stop and the stability of the vehicle at the time of braking. This test is performed under wet and dry road conditions for a vehicle which has both a driver and a front passenger. The distance it takes for the vehicle to stop and the stability of the vehicle at the time of braking is evaluated for when the vehicle is stopped abruptly while traveling at a speed of 100km/h. The stopping distance and vehicle speed have been measured by using GPS since FY2009.

THEREFORE, NO RESPONSIBILITY IS ASSUMED BY CAR VX, LTD OR ITS AGENTS FOR ERRORS OR OMISSIONS IN THIS REPORT. CAR VX, LTD FURTHER EXPRESSLY DISCLAIMS ALL WARRANTIES, EXPRESSED OR IMPLIED, INCLUDING ANY IMPLIED WARRANTIES OF MERCHANTABILITY OR FITNESS FOR A PARTICULAR PURPOSE.

© 2014-2026 Car VX Limited. All rights reserved.