



# Vehicle History Report

## VEHICLE DETAILS

**Chassis number <sup>1</sup>:** GGH20-8018912

**Manufacture date:** 2008-12

**Make:** TOYOTA

**Model:** VELLFIRE

**Body:** DBA-GGH20W

**Grade:** 3.5 Z G EDITION

**Engine:** 2GR-FE

**Drive:** 2WD

**Transmission:** AT

**Title information <sup>2</sup>:**



**Registered**



**Accident / Repair:**



**No problem**



**Odometer rollback:**



**No problem**



**Manufacturer recall:**



**No problem**



**Safety grade <sup>3</sup>:**



★★★★★★



**Contamination risk:**



**No problem**



This CAR VX Vehicle History Report is based only on Information supplied to CAR VX, LTD and available as of 2026-05-31 21:14:10. Other information about this vehicle, including problems, may not have been reported to CAR VX, LTD . Use this report as one important tool, along with a vehicle inspection and test drive, to make a better decision about your next used car.

## ACCIDENT / REPAIR HISTORY

Problem type	Reported	Date reported	Data source	Details	Airbag
Collision	Not reported				
Malfunction	Not reported				
Theft	Not reported				
Fire damage	Not reported				
Water damage	Not reported				
Hail damage	Not reported				

## ODOMETER READINGS HISTORY

Date reported	Data source	Odometer reading (Km)
2023-12-04	MLIT	78500
2025-12-01	MLIT	90900
2026-05-19	USS Yokohama	94021

## USE HISTORY

<b>Use in the contaminated regions</b> <sup>4</sup>	<b>Radioactive contamination test fail</b> <sup>5</sup>	<b>Commercial use</b>
Not reported	Not reported	Not reported

## DETAILED HISTORY

Event date	Location	Odometer reading (Km)	Data source	Details
2008-12			TOYOTA	Manufactured
2008-12			MLIT	First registration
2023-12-04		78500	MLIT	Inspection
2024-03-19	Sagami		MLIT	Last registration
2025-12-01	Sagami	90900	MLIT	Inspection

## MANUFACTURER RECALL HISTORY

Date reported	Data source	Affected part	Details
 Not reported			

## VEHICLE ASSESSMENT <sup>6</sup>

### Overall Collision Safety Ratings

Driver's seat			Front passenger's seat		
Points	Evaluation	Goal average	Points	Evaluation	Goal average
34.46	★★★★★★	96%	23.51	★★★★★★	98%

\* In order to accurately differentiate between the evaluations of different vehicles, a standard is set based on current technology. Up to 6 points out of 12 is given level 1 and the rest of the range is divided up into equal parts, which are respectively assigned to level 2 (more than 6 points but 7.5 or less), level 3 (more than 7.5 points but 9 or less), level 4 (more than 9 points but 10.5 or less) or level 5 (more than 10.5 points).

### Braking performance tests <sup>7</sup>

Dry road



41.7 m

Wet road



47.1 m

## VEHICLE SPECIFICATION

<b>1st gear ratio</b>	3.300	<b>2nd gear ratio</b>	1.900
-----------------------	-------	-----------------------	-------

<b>3rd gear ratio</b>	1.420	<b>4th gear ratio</b>	1.000
-----------------------	-------	-----------------------	-------

<b>5th gear ratio</b>	0.713	<b>6th gear ratio</b>	0.608
-----------------------	-------	-----------------------	-------

<b>Additional notes</b>	NFTSK	<b>Airbag position, capacity</b>	-
-------------------------	-------	----------------------------------	---

<b>Body rear overhang</b>	1015	<b>Body type</b>	MV&1BOX
---------------------------	------	------------------	---------

<b>Chassis number embossing position</b>	FRONT FLOOR CROSSMEMBER RIGHT SIDE ON SURFACE	<b>Classification code</b>	0045
<b>Cylinders</b>		<b>Displacement</b>	3450
<b>Electric engine type</b>	-	<b>Electric engine maximum output</b>	-
<b>Electric engine maximum torque</b>	-	<b>Electric engine power</b>	-
<b>Engine maximum power</b>	206/6200( NET)	<b>Engine maximum torque</b>	344/4700( NET)
<b>Engine model</b>	2GR-FE	<b>Frame type</b>	SOLID STRUCTURE
<b>Front shaft weight</b>	1160	<b>Front shock absorber type</b>	
<b>Front stabilizer type</b>	TORSION BAR TYPE	<b>Front tires size</b>	235/50R18 97V
<b>Front tread</b>	1555	<b>Fuel consumption</b>	9.2
<b>Fuel tank equipment</b>	65	<b>Grade</b>	3.5 Z G EDITION
<b>Height</b>	1900	<b>Length</b>	4865
<b>Main brakes type</b>	HYDRAULIC TYPE, DISK HYDRAULIC TYPE, DISK	<b>Make</b>	TOYOTA
<b>Maximum speed</b>	180	<b>Minimum ground clearance</b>	170
<b>Minimum turning radius</b>	5.9	<b>Model</b>	VELLFIRE
<b>Model code</b>	DBA-GGH20W	<b>Mufflers number</b>	
<b>Rear shaft weight</b>	890	<b>Rear shock absorber type</b>	
<b>Rear stabilizer type</b>	-	<b>Rear tires size</b>	235/50R18 97V
<b>Rear tread</b>	1560	<b>Reverse ratio</b>	4.148
<b>Riding capacity</b>	7	<b>Side brakes type</b>	
<b>Specification code</b>	16088	<b>Stopping distance</b>	50(100)
<b>Transmission type</b>	AT	<b>Weight</b>	2050
<b>Wheel alignment</b>	2WD	<b>Wheelbase</b>	2950

## AUCTION DATA

**Date: 2026-05-19, Auction: USS Yokohama, Lot #: 64059**

Date:	2026-05-19	Lot #:	64059
Auction name:	<a href="#">USS Yokohama</a>	Region:	Kanagawa
Make:	TOYOTA	Model:	VELLFIRE
Reg. year:	2008	Mileage (km):	94021
Displacement (cc):	3500	Transmission:	IA
Color:	PEARL	Model code:	GGH20W
Result:	available	Auction grade:	4.5
Problem type:	No problem	Problem scale:	None
Contaminated:	No	Airbag:	OK

## PHOTOS AND AUCTION SHEETS

# 20MAXコーナー

64059	車種 (車検用には記入)		排気量	型式	4.5
			3500	DBA-GGH20W	
初年度登録年月	車名	グレード	駆動		
H20/12月	トヨタ ヴェルファイア	3.5Z Gエディション	2WD		
車検 R9年12月11日			シフト IAT	特注品	
走行 94,021 km			冷房 AAC	SR (有) カワ	PS (有) ナビ
外色	色番	カラー名	セレスポイント アドミレクション マフラー・Rスポイラー Fグリル ROMAN フスボイラー クリスタルアイ テールランプ 6 Sサス 社外22インチAM ETC トヨタプレミアムサウンドシステム	TV (有) EAP (有)	
内装	色番	カラー名			
燃料	ガソリン		有		
輸入区分	ハンドル	月	日		
リサイクル料	18,290円	乗車定員	7人	登録地	相模 344 つ 1000
○注意事項 (納車・不具合等による状態等)			車台	GGH20-8018912	
整備手帳・取説・ナビ取説 後日			シリアル		

純正AM (冬タイヤ)・テール・グリル他 横込み  
タイトジャパン ヒッチメンバー付き

### ○検査員報告

ハンドルスレ  
ルーム内汚れ、キズ  
ホイールキズ

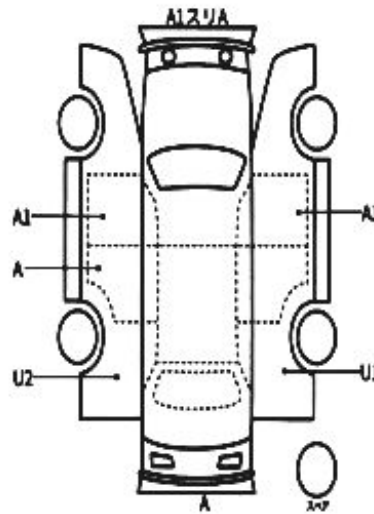

[荷台内寸]約			BOX (cm)		
長さ	幅	高さ	x	x	(cm)
486 cm	184 cm	190 cm			

**1 Chassis number** – a unique identification number of the vehicle in Japan (same as VIN in the USA or Europe)

**2 Title information:**

Registered – qualified for driving in Japan

Deregistered Temporarily – not qualified for driving in Japan, usually a temporary title during the ownership change

Deregistered Completely – not qualified for driving in Japan, the vehicle is determined to be scrapped

Deregistered to Export – not qualified for driving in Japan, the vehicle is determined to be exported

**3 Determining the overall collision safety performance evaluation** – For the driver's seat, the results of the full-wrap frontal collision test, offset frontal collision test, and side collision test are added together and evaluated to 6 different levels. For the Frontal passenger's seat, the results of the full-wrap frontal collision test and the side collision test (results for the driver's or the front passenger's seat are used) are added together and evaluated to 6 different levels.

Regular vehicle inspection – All vehicles in Japan must undergo regular vehicle inspections (shaken). New cars need to be tested after three years, and then vehicles must be tested every two years thereafter. A vehicle inspection (shaken) is compulsory for all vehicles with an engine size over 250cc. It ensures that all vehicles on the road are properly maintained and safe to drive. The test also checks that vehicles have not been illegally modified; if they are found to have been modified, they are not allowed on the road.

**4 Use in the contaminated regions** – The Fukushima Daiichi nuclear disaster was a catastrophic failure at the Fukushima I Nuclear Power Plant on 11 March 2011, resulting in a meltdown of three of the plant's six nuclear reactors. As a result, some areas in the following prefectures were contaminated: Fukushima, Miyagi, Ibaraki, Tochigi.

**5 Radioactive contamination test** – radioactive contamination inspection that was started in July 2011 as a preventive measure for exporting contaminated vehicles from Japan. The inspection is being conducted since in all sea ports of Japan under the supervision of The Japan Harbor Transportation Association (JHTA).

MLIT – Ministry of Land, Infrastructure, Transport and Tourism.

**6 Japan New Car Assessment Program** – the Ministry of Land, Infrastructure, Transport and Tourism (MLIT) and the National Agency for Automotive Safety & Victims' Aid (NASVA) have taken measures for safety, one of which is to assess commercially available vehicles through a variety of safety performance tests and release the resulting information compiled into the "New Car Assessment Program". The objective of Japan New Car Assessment Program is to increase the use of safe automobiles by providing an environment in which users can easily select such vehicles. This also promotes the development of safer vehicles by automobile manufacturers. Neck injury protection for rear-end collision performance test, rear seat passenger's protection for frontal collision performance test, rear passenger's seat belt usability evaluation test and seat belt reminder for passengers evaluation test are started in FY2009.

**7 Braking Performance Tests** – Braking performance is determined by the shortness of the distance in which a vehicle can stop and the stability of the vehicle at the time of braking. This test is performed under wet and dry road conditions for a vehicle which has both a driver and a front passenger. The distance it takes for the vehicle to stop and the stability of the vehicle at the time of braking is evaluated for when the vehicle is stopped abruptly while traveling at a speed of 100km/h. The stopping distance and vehicle speed have been measured by using GPS since FY2009.

THEREFORE, NO RESPONSIBILITY IS ASSUMED BY CAR VX, LTD OR ITS AGENTS FOR ERRORS OR OMISSIONS IN THIS REPORT. CAR VX, LTD FURTHER EXPRESSLY DISCLAIMS ALL WARRANTIES, EXPRESSED OR IMPLIED, INCLUDING ANY IMPLIED WARRANTIES OF MERCHANTABILITY OR FITNESS FOR A PARTICULAR PURPOSE.

© 2014-2026 Car VX Limited. All rights reserved.