



Vehicle History Report

VEHICLE DETAILS

Chassis number ¹: RK5-1003352

Manufacture date: 2009-10-29

Make: HONDA

Model: STEPWGN SPADA

Body: DBA-RK5

Grade: SPADA S

Engine: R20A

Drive: 2WD

Transmission: AT

Title information ²:



Deregistered to Export



Accident / Repair:



No problem



Odometer rollback:



No problem



Manufacturer recall:



No problem



Safety grade ³:



★★★★★



Contamination risk:



No problem



This vehicle does not qualify for Buyback Guarantee

Average Market Price



Unfortunately, this vehicle does not qualify for our Buyback Guarantee program.

[About Buyback Guarantee](#)



¥300,000

This CAR VX Vehicle History Report is based only on Information supplied to CAR VX, LTD and available as of 2023-02-07 23:41:15. Other information about this vehicle, including problems, may not have been reported to CAR VX, LTD . Use this report as one important tool, along with a vehicle inspection and test drive, to make a better decision about your next used car.

ACCIDENT / REPAIR HISTORY

Problem type	Reported	Date reported	Data source	Details	Airbag
Collision	Not reported				
Malfunction	Not reported				
Theft	Not reported				
Fire damage	Not reported				
Water damage	Not reported				
Hail damage	Not reported				

ODOMETER READINGS HISTORY

Date reported	Data source	Odometer reading (Km)
2018-10-19	MLIT	85200
2020-10-26	MLIT	101000
2022-12-17	USS Gunma	135419

USE HISTORY

Use in the contaminated regions ⁴	Radioactive contamination test fail ⁵	Commercial use
Not reported	Not reported	Not reported

DETAILED HISTORY

Event date	Location	Odometer reading (Km)	Data source	Details
2009-10-29			HONDA	Manufactured
2009-11			MLIT	First registration
2018-10-19		85200	MLIT	Inspection
2020-10-26	Matsumoto	101000	MLIT	Inspection
2022-11-18	Matsumoto		MLIT	Last registration

MANUFACTURER RECALL HISTORY

Date reported	Data source	Affected part	Details
---------------	-------------	---------------	---------

 Not reported

VEHICLE ASSESSMENT ⁶

Overall Collision Safety Ratings

Driver's seat			Front passenger's seat		
Points	Evaluation	Goal average	Points	Evaluation	Goal average
34.68	★★★★★★	96%	22.89	★★★★★★	95%

* In order to accurately differentiate between the evaluations of different vehicles, a standard is set based on current technology. Up to 6 points out of 12 is given level 1 and the rest of the range is divided up into equal parts, which are respectively assigned to level 2 (more than 6 points but 7.5 or less), level 3 (more than 7.5 points but 9 or less), level 4 (more than 9 points but 10.5 or less) or level 5 (more than 10.5 points).

Braking performance tests ⁷

Dry road  40.6 m

Wet road  43.6 m

VEHICLE SPECIFICATION

1st gear ratio	2.470 ~ 0.450(MANUAL MODE ATTACHING)	2nd gear ratio	-
3rd gear ratio	-	4th gear ratio	-
5th gear ratio	-	6th gear ratio	-
Additional notes	-	Airbag position, capacity	-

Body rear overhang	950	Body type	STATION WAGON
Chassis number embossing position	BONNET INSIDE DASH BOARD UPPER FRONT SURFACE	Classification code	0011
Cylinders	4	Displacement	1990
Electric engine type	-	Electric engine maximum output	-
Electric engine maximum torque	-	Electric engine power	-
Engine maximum power	110/6200(NET)	Engine maximum torque	193/4200(NET)
Engine model	R20A	Frame type	SOLID STRUCTURE
Front shaft weight	920	Front shock absorber type	
Front stabilizer type	TORSION· BAR TYPE	Front tires size	205/60R16 92H DESIGNATION EQUIPMENT ETC.... TIRE CLASSIFICATION EXCEPTING 205/55R17 91V DESIGNATION EQUIPMENT ETC.... TIRE CLASSIFICATION
Front tread	1.470	Fuel consumption	14.0
Fuel tank equipment	60	Grade	SPADA S
Height	1.815	Length	4.690
Main brakes type	HYDRAULIC TYPE· FRONT DISK· BACK DISK	Make	HONDA
Maximum speed	180(推定)	Minimum ground clearance	0.155
Minimum turning radius	5.3... TIRE CLASSIFICATION EXCEPTING 5.6... TIRE CLASSIFICATION	Model	STEPWGN SPADA

Model code	DBA-RK5	Mufflers number	
Rear shaft weight	700	Rear shock absorber type	
Rear stabilizer type	TORSION BAR TYPE	Rear tires size	205/60R16 92H DESIGNATION EQUIPMENT ETC.... TIRE CLASSIFICATION EXCEPTING 205/55R17 91V DESIGNATION EQUIPMENT ETC.... TIRE CLASSIFICATION
Rear tread	1.460	Reverse ratio	1.735 ~ 1.214
Riding capacity	8	Side brakes type	MACHINE CAR WHEEL 制動 SHAPE(DRUM TYPE)
Specification code	16365	Stopping distance	53(100)
Transmission type	AT	Weight	1620
Wheel alignment	2WD	Wheelbase	2.855
Width	1.695		

AUCTION DATA

Date: 2022-12-17, Auction: USS Gunma, Lot #: 7107

Date:	2022-12-17	Lot #:	7107
Auction name:	USS Gunma	Region:	Gunma
Make:	HONDA	Model:	STEPWGN SPADA
Reg. year:	2009	Mileage (km):	135419
Displacement (cc):	2000	Transmission:	IA
Color:	BLACK	Model code:	RK5
Result:	available	Auction grade:	3.5
Problem type:	No problem	Problem scale:	None
Contaminated:	No	Airbag:	OK

PHOTOS AND AUCTION SHEETS

ロープラ10コーナー

7107	車種 (自家用以外は記入) 排気量	型式	評価点 3.5
	2000 DBA-RK5		
	初年度登録年月 車名	グレード	
21/11月	ステップワゴン	5D SPADAS	4WD
			内容 検定印記

車検	X年 X月	ソフト	IAT	特注	SH	MAN	CB	SW
走行	135,419 km	冷房	AAC	カーナビ	カワ	TV	8	8
外色	元色 色調	カラー	有・無	カーナビ	有・無	カーナビ	有・無	カーナビ
外色	20本	PB81P	有・無	カーナビ	有・無	カーナビ	有・無	カーナビ
内装	カーナビ	カーナビ	カーナビ	カーナビ	カーナビ	カーナビ	カーナビ	カーナビ
輸入	ディーラー	並行	左	右	月	日		

リサイクル 特売金	13940円	乗車定員	8人	登録地	
登録台帳	RK5-1003352	シリアル			

- 注意事項 (車検 不具合箇所ある(付記事項))
- ★ドアヒーター - 88
 - ★リアドアヒーター - 88
 - ★フロントドアヒーター - 88
 - ★ナビ付 - 88
 - ★安全シート - 88
- 検査員報告 (USS使用機)
- 79.3v
 - 10.0v
 - 10.0v
 - 10.0v

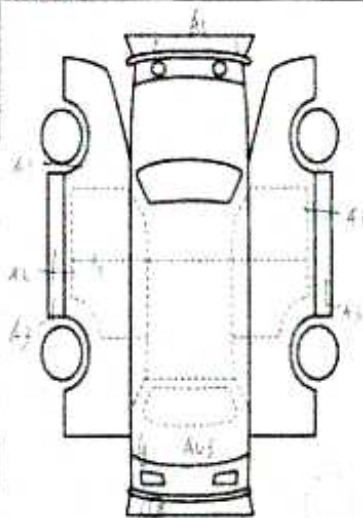

【荷台内寸】約 X X (cm)

長さ 幅 高さ (車検証上の寸法) A1 スペース





¹ Chassis number – a unique identification number of the vehicle in Japan (same as VIN in the USA or Europe)

² Title information:

Registered – qualified for driving in Japan

Deregistered Temporarily – not qualified for driving in Japan, usually a temporary title during the ownership change

Deregistered Completely – not qualified for driving in Japan, the vehicle is determined to be scrapped

Deregistered to Export – not qualified for driving in Japan, the vehicle is determined to be exported

³ Determining the overall collision safety performance evaluation – For the driver's seat, the results of the full-wrap frontal collision test, offset frontal collision test, and side collision test are added together and evaluated to 6 different levels. For the Frontal passenger's seat, the results of the full-wrap frontal collision test and the side collision test (results for the driver's or the front passenger's seat are used) are added together and evaluated to 6 different levels.

Regular vehicle inspection – All vehicles in Japan must undergo regular vehicle inspections (shaken). New cars need to be tested after three years, and then vehicles must be tested every two years thereafter. A vehicle inspection (shaken) is compulsory for all vehicles with an engine size over 250cc. It ensures that all vehicles on the road are properly maintained and safe to drive. The test also checks that vehicles have not been illegally modified; if they are found to have been modified, they are not allowed on the road.

⁴ Use in the contaminated regions – The Fukushima Daiichi nuclear disaster was a catastrophic failure at the Fukushima I Nuclear Power Plant on 11 March 2011, resulting in a meltdown of three of the plant's six nuclear reactors. As a result, some areas in the following prefectures were contaminated: Fukushima, Miyagi, Ibaraki, Tochigi.

⁵ Radioactive contamination test – radioactive contamination inspection that was started in July 2011 as a preventive measure for exporting contaminated vehicles from Japan. The inspection is being conducted since in all sea ports of Japan under the supervision of The Japan Harbor Transportation Association (JHTA).

MLIT – Ministry of Land, Infrastructure, Transport and Tourism.

⁶ Japan New Car Assessment Program – the Ministry of Land, Infrastructure, Transport and Tourism (MLIT) and the National Agency for Automotive Safety & Victims' Aid (NASVA) have taken measures for safety, one of which is to assess commercially available vehicles through a variety of safety performance tests and release the resulting information compiled into the "New Car Assessment Program". The objective of Japan New Car Assessment Program is to increase the use of safe automobiles by providing an environment in which users can easily select such vehicles. This also promotes the development of safer vehicles by automobile manufacturers. Neck injury protection for rear-end collision performance test, rear seat passenger's protection for frontal collision performance test, rear passenger's seat belt usability evaluation test and seat belt reminder for passengers evaluation test are started in FY2009.

⁷ Braking Performance Tests – Braking performance is determined by the shortness of the distance in which a vehicle can stop and the stability of the vehicle at the time of braking. This test is performed under wet and dry road conditions for a vehicle which has both a driver and a front passenger. The distance it takes for the vehicle to stop and the stability of the vehicle at the time of braking is evaluated for when the vehicle is stopped abruptly while traveling at a speed of 100km/h. The stopping distance and vehicle speed have been measured by using GPS since FY2009.

CAR VX, LTD DEPENDS ON ITS SOURCES FOR THE ACCURACY AND RELIABILITY OF ITS INFORMATION. THEREFORE, NO RESPONSIBILITY IS ASSUMED BY CAR VX, LTD OR ITS AGENTS FOR ERRORS OR OMISSIONS IN THIS REPORT. CAR VX, LTD FURTHER EXPRESSLY DISCLAIMS ALL WARRANTIES, EXPRESS OR IMPLIED, INCLUDING ANY IMPLIED WARRANTIES OF MERCHANTABILITY OR FITNESS FOR A PARTICULAR PURPOSE.

© 2014-2023 Car VX Limited. All rights reserved.