



Vehicle History Report

VEHICLE DETAILS

Chassis number ¹: ANH10-0197076

Manufacture date: 2008-01

Make: TOYOTA

Model: ALPHARD G

Body: DBA-ANH10W

Grade: 2.4AS PRIME SELECTION II

Engine: 2AZ-FE

Drive: 2WD

Transmission: AT

Title information ²:



Deregistered to Export



Accident / Repair:



No problem



Odometer rollback:



No problem



Manufacturer recall:



No problem



Safety grade ³:



★★★★★



Contamination risk:



No problem



This vehicle does not qualify for Buyback Guarantee

Average Market Price



Unfortunately, this vehicle does not qualify for our Buyback Guarantee program.



¥470,000

[About Buyback Guarantee](#)

This CAR VX Vehicle History Report is based only on Information supplied to CAR VX, LTD and available as of 2023-02-08 03:22:37. Other information about this vehicle, including problems, may not have been reported to CAR VX, LTD. Use this report as one important tool, along with a vehicle inspection and test drive, to make a better decision about your next used car.

ACCIDENT / REPAIR HISTORY

Problem type	Reported	Date reported	Data source	Details	Airbag
Collision	Not reported				
Malfunction	Not reported				
Theft	Not reported				
Fire damage	Not reported				
Water damage	Not reported				
Hail damage	Not reported				

ODOMETER READINGS HISTORY

Date reported	Data source	Odometer reading (Km)
2019-03-12	MLIT	86800
2021-03-16	MLIT	99800
2022-12-15	JU Aichi	107361
2022-12-23	LAA Okayama	107361

USE HISTORY

Use in the contaminated regions ⁴	Radioactive contamination test fail ⁵	Commercial use
Not reported	Not reported	Not reported

DETAILED HISTORY

Event date	Location	Odometer reading (Km)	Data source	Details
2008-01			TOYOTA	Manufactured
2008-03			MLIT	First registration
2019-03-12		86800	MLIT	Inspection
2021-03-16	Yokohama	99800	MLIT	Inspection

2022-12-15	Aichi	107361	JU Aichi	Auctioned
2022-12-23	Okayama	107361	LAA Okayama	Auctioned
2023-01-10	Yokohama		MLIT	Last registration

MANUFACTURER RECALL HISTORY

Date reported	Data source	Affected part	Details
---------------	-------------	---------------	---------

 Not reported

VEHICLE ASSESSMENT ⁶

Overall Collision Safety Ratings

Driver's seat			Front passenger's seat		
Points	Evaluation	Goal average	Points	Evaluation	Goal average
32.48	★★★★★★	90%	22.74	★★★★★★	95%

* In order to accurately differentiate between the evaluations of different vehicles, a standard is set based on current technology. Up to 6 points out of 12 is given level 1 and the rest of the range is divided up into equal parts, which are respectively assigned to level 2 (more than 6 points but 7.5 or less), level 3 (more than 7.5 points but 9 or less), level 4 (more than 9 points but 10.5 or less) or level 5 (more than 10.5 points).

Braking performance tests ⁷

Dry road		45.3 m
Wet road		49.0 m

VEHICLE SPECIFICATION

1st gear ratio	3.943	2nd gear ratio	2.197
3rd gear ratio	1.413	4th gear ratio	1.020
5th gear ratio	-	6th gear ratio	-
Additional notes	PRPSK	Airbag position, capacity	-

Body rear overhang	1035	Body type	STATION WAGON
Chassis number embossing position	COWL TOP PANEL CENTRE	Classification code	0130
Cylinders	4	Displacement	2360
Electric engine type	-	Electric engine maximum output	-
Electric engine maximum torque	-	Electric engine power	-
Engine maximum power	117/5600(NET)	Engine maximum torque	220/4000(NET)
Engine model	2AZ-FE	Frame type	SOLID STRUCTURE
Front shaft weight	990	Front shock absorber type	
Front stabilizer type	TORSION BAR TYPE	Front tires size	205/65R16 95H 225/55R17 95W
Front tread	1560 1570	Fuel consumption	9.7
Fuel tank equipment	70	Grade	2.4AS PRIME SELECTION II
Height	1935	Length	4865
Main brakes type	HYDRAULIC TYPE DISK HYDRAULIC TYPE DISK	Make	TOYOTA
Maximum speed	170	Minimum ground clearance	160
Minimum turning radius	5.6 5.8	Model	ALPHARD G
Model code	DBA-ANH10W	Mufflers number	
Rear shaft weight	810	Rear shock absorber type	
Rear stabilizer type	TORSION BAR TYPE	Rear tires size	205/65R16 95H 225/55R17 95W
Rear tread	1540 1550	Reverse ratio	3.145
Riding capacity	8	Side brakes type	MACHINE CAR WHEEL制動 SHAPE
Specification code	15028	Stopping distance	56(100)
Transmission type	AT	Weight	1800

Wheel alignment	2WD	Wheelbase	2900
Width	1830		

AUCTION DATA

Date: 2022-12-15, Auction: JU Aichi, Lot #: 30274

Date:	2022-12-15	Lot #:	30274
Auction name:	JU Aichi	Region:	Aichi
Make:	TOYOTA	Model:	ALPHARD
Reg. year:	2008	Mileage (km):	107361
Displacement (cc):	2400	Transmission:	AT
Color:	PEARL	Model code:	ANH10W
Result:	sold	Auction grade:	3.5
Problem type:	No problem	Problem scale:	None
Contaminated:	No	Airbag:	OK

Date: 2022-12-23, Auction: LAA Okayama, Lot #: 4280

Date:	2022-12-23	Lot #:	4280
Auction name:	LAA Okayama	Region:	Okayama
Make:	TOYOTA	Model:	ALPHARD
Reg. year:	2008	Mileage (km):	107361
Displacement (cc):	2400	Transmission:	AT
Color:	PEARL	Model code:	ANH10W
Result:	sold	Auction grade:	3.5
Problem type:	No problem	Problem scale:	None
Contaminated:	No	Airbag:	OK

PHOTOS AND AUCTION SHEETS

車内保管・守衛保管

愛知 出品申込書 JAPAN USED CAR DEALERS ASSOCIATION

出品番号 [1993] 30274	初度登録年月 20 3 月	車名・グレード ALPHARD 2.4AS PRIME SELECTION II	2WD 4WD	評価点 3.5
	型式 DBA- ANH10W	排気量 2.36 CC	ドア 定員 8 人	ディーラー・並行 モデル 年式 ハンドル 左・右

車歴 自家用・() 車検 5 年 3 月 (15 日) 受検形態 車検付きのみ記入して下さい () 走行 10万7千361 km 色 ハロ-1V 色替 色コード 070	シフト AT 冷房 AAC 燃料 <u>ガソリン</u> 軽油 ()	セールスポイント(正常に機能するものに限ります) HALF LEATHER TV NAVI ETC GPS BACK CAMRA POWER SLIDE DOOR
R券 14480 円 名変期限 月 日 注意事項申告欄(不具合内容等は具体的に記入して下さい)	後日品	装備品(純正品に限り○をつけてください) PS SR ○ PW ナビ ○ APB TV ○ AW ○ 新車保証書 有・無

修復歴 有 (箇所)

検査員 記入欄
 FW キズ・龜石・ヒビ割・リペア跡・X 要
 内装 キズ・酒・コゲ・穴・ズレ・キレ・破レ

天張ソウキ
 シート171, シ7, ビ
 AWカメラ-A
 各AV

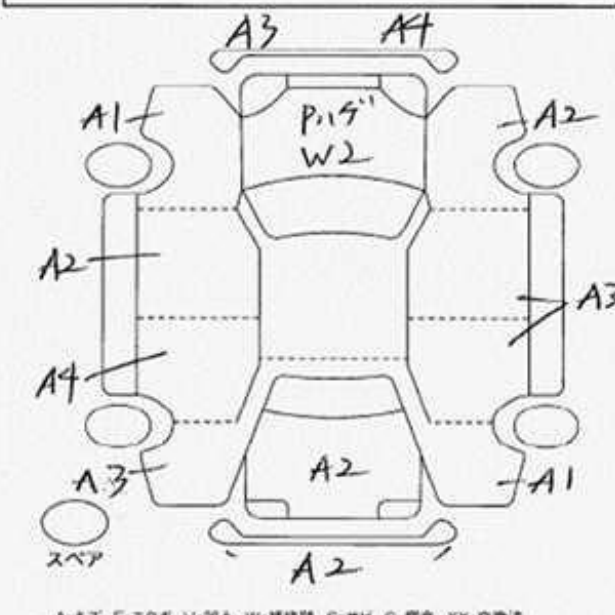

A-キズ E-エウボ U-凹み W-補修跡 S-サビ C-腐食 XX-交換済

形式指定番号	別区分番号
車庫証明用参考	長さ cm 幅 cm 高さ cm

車台番号 ANH10-0197076
 登録番号 宮 331 ま 118 8









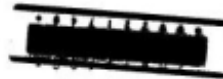

LAA 出品申込書

出品番号 4280	初度登録年月 20年 月	車名 アルファード	ドア 5W	形状 AS70714EUA2II	グレード	評価点 3.5
車種 自家用()	型式 DBA-ANH10W	排気量 2X00cc	定員 人			
車検 25年3月15日	フロア AD	コラム タコ	MTのみの記入 速	セルシスポイント コネクター ETC-HID パワーウィンドウ スマートドア	[外装] B	[内装] B
走行 107361	外装色 110-16	色替車は色替と記入	冷房 AAC	燃料 ガソリン・軽油()	PS (1100cc)	SR (1970cc)
内装色 070	輸入車	モデル年式 年・不明	D車・並	右・左	純正品のみ丸印	
新車保証書 取得済	取扱説明書 R券 ¥18,880	名変期限 月 日迄	車台番号 ANH10-0197076			
注意事項 後日品【 不具合箇所等 純正ナビ・パワーウィンドウ・パワードア 11-7LQニート						
検査員記入 ガラス X要ス シート Xコゲ・穴・汚れ・破れ ヘッドシートス ナビA ドアA						
長さ cm	幅 cm	高さ cm	積載量 kg			

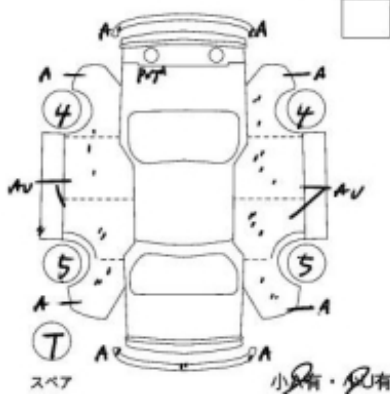





¹ Chassis number – a unique identification number of the vehicle in Japan (same as VIN in the USA or Europe)

² Title information:

Registered – qualified for driving in Japan

Deregistered Temporarily – not qualified for driving in Japan, usually a temporary title during the ownership change

Deregistered Completely – not qualified for driving in Japan, the vehicle is determined to be scrapped

Deregistered to Export – not qualified for driving in Japan, the vehicle is determined to be exported

³ Determining the overall collision safety performance evaluation – For the driver's seat, the results of the full-wrap frontal collision test, offset frontal collision test, and side collision test are added together and evaluated to 6 different levels. For the Frontal passenger's seat, the results of the full-wrap frontal collision test and the side collision test (results for the driver's or the front passenger's seat are used) are added together and evaluated to 6 different levels.

Regular vehicle inspection – All vehicles in Japan must undergo regular vehicle inspections (shaken). New cars need to be tested after three years, and then vehicles must be tested every two years thereafter. A vehicle inspection (shaken) is compulsory for all vehicles with an engine size over 250cc. It ensures that all vehicles on the road are properly maintained and safe to drive. The test also checks that vehicles have not been illegally modified; if they are found to have been modified, they are not allowed on the road.

⁴ Use in the contaminated regions – The Fukushima Daiichi nuclear disaster was a catastrophic failure at the Fukushima I Nuclear Power Plant on 11 March 2011, resulting in a meltdown of three of the plant's six nuclear reactors. As a result, some areas in the following prefectures were contaminated: Fukushima, Miyagi, Ibaraki, Tochigi.

⁵ Radioactive contamination test – radioactive contamination inspection that was started in July 2011 as a preventive measure for exporting contaminated vehicles from Japan. The inspection is being conducted since in all sea ports of Japan under the supervision of The Japan Harbor Transportation Association (JHTA).

MLIT – Ministry of Land, Infrastructure, Transport and Tourism.

⁶ Japan New Car Assessment Program – the Ministry of Land, Infrastructure, Transport and Tourism (MLIT) and the National Agency for Automotive Safety & Victims' Aid (NASVA) have taken measures for safety, one of which is to assess commercially available vehicles through a variety of safety performance tests and release the resulting information compiled into the "New Car Assessment Program". The objective of Japan New Car Assessment Program is to increase the use of safe automobiles by providing an environment in which users can easily select such vehicles. This also promotes the development of safer vehicles by automobile manufacturers. Neck injury protection for rear-end collision performance test, rear seat passenger's protection for frontal collision performance test, rear passenger's seat belt usability evaluation test and seat belt reminder for passengers evaluation test are started in FY2009.

⁷ Braking Performance Tests – Braking performance is determined by the shortness of the distance in which a vehicle can stop and the stability of the vehicle at the time of braking. This test is performed under wet and dry road conditions for a vehicle which has both a driver and a front passenger. The distance it takes for the vehicle to stop and the stability of the vehicle at the time of braking is evaluated for when the vehicle is stopped abruptly while traveling at a speed of 100km/h. The stopping distance and vehicle speed have been measured by using GPS since FY2009.

CAR VX, LTD DEPENDS ON ITS SOURCES FOR THE ACCURACY AND RELIABILITY OF ITS INFORMATION. THEREFORE, NO RESPONSIBILITY IS ASSUMED BY CAR VX, LTD OR ITS AGENTS FOR ERRORS OR OMISSIONS IN THIS REPORT. CAR VX, LTD FURTHER EXPRESSLY DISCLAIMS ALL WARRANTIES, EXPRESS OR IMPLIED, INCLUDING ANY IMPLIED WARRANTIES OF MERCHANTABILITY OR FITNESS FOR A PARTICULAR PURPOSE.

© 2014-2023 Car VX Limited. All rights reserved.