

VEHICLE DETAILS

Chassis number ¹: HA4-2416153

Manufacture date: 1999

Make: HONDA

Model: ACTY TRUCK

Body: V-HA4

Grade: SDX

Engine: E07A

Drive: 4WD

Transmission: F5

Title information ²:



Deregistered to Export



Accident / Repair:



No problem



Odometer rollback:



No problem



Manufacturer recall:



No problem



Safety grade ³:



No data



Contamination risk:



No problem



This vehicle does not qualify for Buyback Guarantee

Average Market Price



Unfortunately, this vehicle does not qualify for our Buyback Guarantee program.



¥250,000

[About Buyback Guarantee](#)

This CAR VX Vehicle History Report is based only on Information supplied to CAR VX, LTD and available as of 2023-02-08 01:10:54. Other information about this vehicle, including problems, may not have been reported to CAR VX, LTD . Use this report as one important tool, along with a vehicle inspection and test drive, to make a better decision about your next used car.

ACCIDENT / REPAIR HISTORY

Problem type	Reported	Date reported	Data source	Details	Airbag
Collision	Not reported				
Malfunction	Not reported				
Theft	Not reported				
Fire damage	Not reported				
Water damage	Not reported				
Hail damage	Not reported				

ODOMETER READINGS HISTORY

Date reported	Data source	Odometer reading (Km)
2012-12-06	JU Gunma	58743
2019-02-21	MLIT	120000
2021-02-10	MLIT	123900
2022-12-17	USS Gunma	128000

USE HISTORY

Use in the contaminated regions ⁴	Radioactive contamination test fail ⁵	Commercial use
Not reported	Not reported	Not reported

DETAILED HISTORY

Event date	Location	Odometer reading (Km)	Data source	Details
1999			HONDA	Manufactured
1999-02			MLIT	First registration
2012-12-06	Gunma	58743	JU Gunma	Auctioned
2019-02-21		120000	MLIT	Inspection

2021-02-10		123900	MLIT	Inspection
2022-12-17	Gunma	128000	USS Gunma	Auctioned
2023-01-11	Takasaki		MLIT	Last registration

MANUFACTURER RECALL HISTORY

Date reported	Data source	Affected part	Details
---------------	-------------	---------------	---------

 Not reported

VEHICLE ASSESSMENT ⁶

Overall Collision Safety Ratings

Driver's seat			Front passenger's seat		
Points	Evaluation	Goal average	Points	Evaluation	Goal average

* In order to accurately differentiate between the evaluations of different vehicles, a standard is set based on current technology. Up to 6 points out of 12 is given level 1 and the rest of the range is divided up into equal parts, which are respectively assigned to level 2 (more than 6 points but 7.5 or less), level 3 (more than 7.5 points but 9 or less), level 4 (more than 9 points but 10.5 or less) or level 5 (more than 10.5 points).

Braking performance tests ⁷

Dry road



Wet road



VEHICLE SPECIFICATION

1st gear ratio

2nd gear ratio

3rd gear ratio

4th gear ratio

5th gear ratio

6th gear ratio

Additional notes

Airbag position,
capacity

Body rear overhang		Body type	LIGHT CAR / TRUCK
Chassis number embossing position		Classification code	2
Cylinders	3	Displacement	650
Electric engine type		Electric engine maximum output	
Electric engine maximum torque		Electric engine power	
Engine maximum power	38ps(28kW)/5300rpm	Engine maximum torque	5.5kg·m(54N·m)/4500rpm
Engine model	E07A	Frame type	
Front shaft weight	420	Front shock absorber type	
Front stabilizer type		Front tires size	145R12-6PR
Front tread	1205	Fuel consumption	
Fuel tank equipment	37	Grade	SDX
Height	175	Length	325
Main brakes type		Make	HONDA
Maximum speed		Minimum ground clearance	
Minimum turning radius	3.8m	Model	ACTY TRUCK
Model code	V-HA4	Mufflers number	
Rear shaft weight	300	Rear shock absorber type	
Rear stabilizer type		Rear tires size	145R12-6PR
Rear tread	1215	Reverse ratio	
Riding capacity	2	Side brakes type	
Specification code	6835	Stopping distance	
Transmission type	F5	Weight	720
Wheel alignment	4WD	Wheelbase	1900
Width	139		

Date: 2012-12-06, Auction: JU Gunma, Lot #: 7112

Date:	2012-12-06	Lot #:	7112
Auction name:	JU Gunma	Region:	Gunma
Make:	HONDA	Model:	ACTY TRUCK
Reg. year:	1999	Mileage (km):	58743
Displacement (cc):	660	Transmission:	F5
Color:	WHITE	Model code:	HA4
Result:	sold	Auction grade:	3
Problem type:	No problem	Problem scale:	None
Contaminated:	No	Airbag:	OK

Date: 2022-12-17, Auction: USS Gunma, Lot #: 7117

Date:	2022-12-17	Lot #:	7117
Auction name:	USS Gunma	Region:	Gunma
Make:	HONDA	Model:	ACTY TRUCK
Reg. year:	1999	Mileage (km):	128000
Displacement (cc):	660	Transmission:	F5
Color:	WHITE	Model code:	HA4
Result:	available	Auction grade:	3.5
Problem type:	No problem	Problem scale:	None
Contaminated:	No	Airbag:	OK

PHOTOS AND AUCTION SHEETS

JUオークション出品申込書

①会場控

出品番号 7112	初度登録年月 11 月	車名・グレード ア7テクト7		2WD 4WD	評価点 3
	ディーラー・並行 モラル年式 ハンドル 左・右	型式 V-HA4	排気量 660 cc	ドア 2 形状 T 定員 2人 積載 kg	

車歴 自家用()	シフト F5
車検 25年2月(日)	冷房
走行 5万8千743 km	燃料 ガソリン 軽油
色 白 色管 色コード NH528	()

セールスポイント (正常に機能するもの)

装備品 (純正品に限る)				
PS	PW	ABS	エアB	AW
SR	ナビ	TV	本革	

R券 3460 円 預託済 名実期限 月 日

出品店申告欄 (不良内容・欠品・注意事項等記載)

保証書 有・無 換日品

*7-11-後送

修復歴 有 (箇所)

検査員	FW	キズ・飛石・ヒビ割・リペア跡・X要
記入欄	内装	キズ・汚損・コゲ・穴・スレ・キレ・破レ

シートが裏
キズ、汚れ、スレ

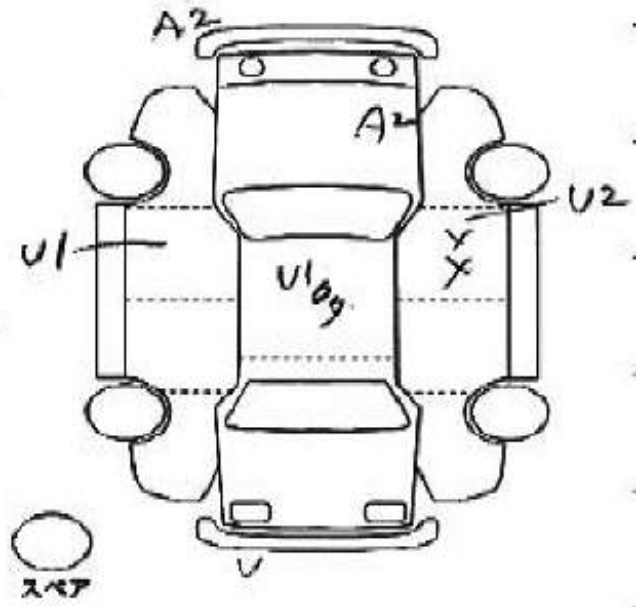

車台番号 HA4-2416153



ロープラ10コーナー

7117	車種 (自動車以外は記入)	研究用	型式	評価点
	0.65		V-HA4	3.5
初年度登録年月	車名	グレード	2WD	内装
11月	ACTY	2		6

車検	年	月	ソフト	F5	特選	S R	MAW	P S	P W
走行	127,804	走行	冷房	有	販売店	カワ	T V	ナビ	E7B
外装色	白	カラー	有・無		セールスポイント				
燃料	ガソリン	内装色	有・無						
輸入車	輸入国	ハンデル	名義変更済						
輸入年月	ディーラー	年月日							
リサイクル	346g	乗車定員	登録地						
検定値	4人		車台号	2416153					
注意事項 (検査 不具合欄等および試乗時)				シリアル					

検査員報告 (USS使用)

D-1000
 天幕シート3枚
 荷台床板
 右側ドア

特別規定あり
 原則ノークレーム

荷台内寸約 X X (cm)
 長さ 幅 高さ (車検上の寸法) スペア

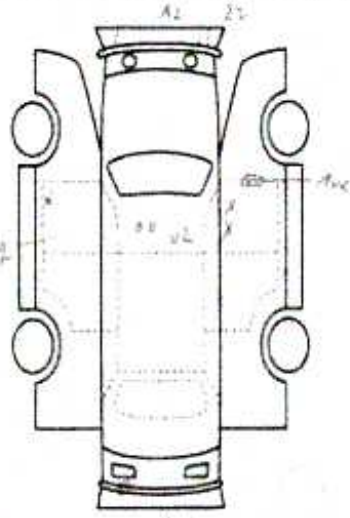



¹ Chassis number – a unique identification number of the vehicle in Japan (same as VIN in the USA or Europe)

² Title information:

Registered – qualified for driving in Japan

Deregistered Temporarily – not qualified for driving in Japan, usually a temporary title during the ownership change

Deregistered Completely – not qualified for driving in Japan, the vehicle is determined to be scrapped

Deregistered to Export – not qualified for driving in Japan, the vehicle is determined to be exported

³ Determining the overall collision safety performance evaluation – For the driver's seat, the results of the full-wrap frontal collision test, offset frontal collision test, and side collision test are added together and evaluated to 6 different levels. For the Frontal passenger's seat, the results of the full-wrap frontal collision test and the side collision test (results for the driver's or the front passenger's seat are used) are added together and evaluated to 6 different levels.

Regular vehicle inspection – All vehicles in Japan must undergo regular vehicle inspections (shaken). New cars need to be tested after three years, and then vehicles must be tested every two years thereafter. A vehicle inspection (shaken) is compulsory for all vehicles with an engine size over 250cc. It ensures that all vehicles on the road are properly maintained and safe to drive. The test also checks that vehicles have not been illegally modified; if they are found to have been modified, they are not allowed on the road.

⁴ Use in the contaminated regions – The Fukushima Daiichi nuclear disaster was a catastrophic failure at the Fukushima I Nuclear Power Plant on 11 March 2011, resulting in a meltdown of three of the plant's six nuclear reactors. As a result, some areas in the following prefectures were contaminated: Fukushima, Miyagi, Ibaraki, Tochigi.

⁵ Radioactive contamination test – radioactive contamination inspection that was started in July 2011 as a preventive measure for exporting contaminated vehicles from Japan. The inspection is being conducted since in all sea ports of Japan under the supervision of The Japan Harbor Transportation Association (JHTA).

MLIT – Ministry of Land, Infrastructure, Transport and Tourism.

⁶ Japan New Car Assessment Program – the Ministry of Land, Infrastructure, Transport and Tourism (MLIT) and the National Agency for Automotive Safety & Victims' Aid (NASVA) have taken measures for safety, one of which is to assess commercially available vehicles through a variety of safety performance tests and release the resulting information compiled into the "New Car Assessment Program". The objective of Japan New Car Assessment Program is to increase the use of safe automobiles by providing an environment in which users can easily select such vehicles. This also promotes the development of safer vehicles by automobile manufacturers. Neck injury protection for rear-end collision performance test, rear seat passenger's protection for frontal collision performance test, rear passenger's seat belt usability evaluation test and seat belt reminder for passengers evaluation test are started in FY2009.

⁷ Braking Performance Tests – Braking performance is determined by the shortness of the distance in which a vehicle can stop and the stability of the vehicle at the time of braking. This test is performed under wet and dry road conditions for a vehicle which has both a driver and a front passenger. The distance it takes for the vehicle to stop and the stability of the vehicle at the time of braking is evaluated for when the vehicle is stopped abruptly while traveling at a speed of 100km/h. The stopping distance and vehicle speed have been measured by using GPS since FY2009.

CAR VX, LTD DEPENDS ON ITS SOURCES FOR THE ACCURACY AND RELIABILITY OF ITS INFORMATION. THEREFORE, NO RESPONSIBILITY IS ASSUMED BY CAR VX, LTD OR ITS AGENTS FOR ERRORS OR OMISSIONS IN THIS REPORT. CAR VX, LTD FURTHER EXPRESSLY DISCLAIMS ALL WARRANTIES, EXPRESS OR IMPLIED, INCLUDING ANY IMPLIED WARRANTIES OF MERCHANTABILITY OR FITNESS FOR A PARTICULAR PURPOSE.

© 2014-2023 Car VX Limited. All rights reserved.