



Vehicle History Report

VEHICLE DETAILS

Chassis number ¹: NGC30-0009904

Manufacture date: 2010-09

Make: TOYOTA

Model: PASSO

Body: DBA-NGC30

Grade: 1.3 + HANA

Engine: 1NR

Drive: 2WD

Transmission: AT

Title information ²:  **Deregistered to Export** 

Accident / Repair:  **No problem** 

Odometer rollback:  **No problem** 

Manufacturer recall:  **No problem** 

Safety grade ³:  **★★★★★** 

Contamination risk:  **No problem** 

This vehicle does not qualify for Buyback Guarantee



Unfortunately, this vehicle does not qualify for our Buyback Guarantee program.

[About Buyback Guarantee](#)

Average Market Price



¥320,000

This CAR VX Vehicle History Report is based only on Information supplied to CAR VX, LTD and available as of 2023-06-08 20:34:25. Other information about this vehicle, including problems, may not have been reported to CAR VX, LTD . Use this report as one important tool, along with a vehicle inspection and test drive, to make a better decision about your next used car.

ACCIDENT / REPAIR HISTORY

| Problem type | Reported | Date reported | Data source | Details | Airbag |
|--------------|--------------|---------------|-------------|---------|--------|
| Collision | Not reported | | | | |
| Malfunction | Not reported | | | | |
| Theft | Not reported | | | | |
| Fire damage | Not reported | | | | |
| Water damage | Not reported | | | | |
| Hail damage | Not reported | | | | |

ODOMETER READINGS HISTORY

| Date reported | Data source | Odometer reading (Km) |
|---------------|--------------|-----------------------|
| 2019-08-20 | MLIT | 25300 |
| 2021-08-24 | MLIT | 28400 |
| 2022-05-12 | MIRIVE Osaka | 29234 |
| 2022-10-19 | JAA HAA | 29240 |
| 2023-05-31 | CAA Chubu | 33501 |

USE HISTORY

| | | |
|---|---|-----------------------|
| Use in the contaminated regions ⁴ | Radioactive contamination test fail ⁵ | Commercial use |
| Not reported | Not reported | Not reported |

DETAILED HISTORY

| Event date | Location | Odometer reading (Km) | Data source | Details |
|------------|----------|-----------------------|-------------|--------------------|
| 2010-09 | | | TOYOTA | Manufactured |
| 2010-09 | | | MLIT | First registration |
| 2019-08-20 | | 25300 | MLIT | Inspection |

| | | | | |
|------------|----------|-------|--------------|-------------------|
| 2021-08-24 | Yokohama | 28400 | MLIT | Inspection |
| 2022-05-12 | Osaka | 29234 | MIRIVE Osaka | Auctioned |
| 2022-10-19 | | 29240 | JAA HAA | Auctioned |
| 2023-05-31 | Aichi | 33501 | CAA Chubu | Auctioned |
| 2023-06-06 | Yokohama | | MLIT | Last registration |

MANUFACTURER RECALL HISTORY

| Date reported | Data source | Affected part | Details |
|---|-------------|---------------|---------|
|  Not reported | | | |

VEHICLE ASSESSMENT ⁶

Overall Collision Safety Ratings

| Driver's seat | | | Front passenger's seat | | |
|---------------|------------|--------------|------------------------|------------|--------------|
| Points | Evaluation | Goal average | Points | Evaluation | Goal average |
| 32.37 | ★★★★★★ | 90% | 21.74 | ★★★★★★ | 91% |

* In order to accurately differentiate between the evaluations of different vehicles, a standard is set based on current technology. Up to 6 points out of 12 is given level 1 and the rest of the range is divided up into equal parts, which are respectively assigned to level 2 (more than 6 points but 7.5 or less), level 3 (more than 7.5 points but 9 or less), level 4 (more than 9 points but 10.5 or less) or level 5 (more than 10.5 points).

Braking performance tests ⁷

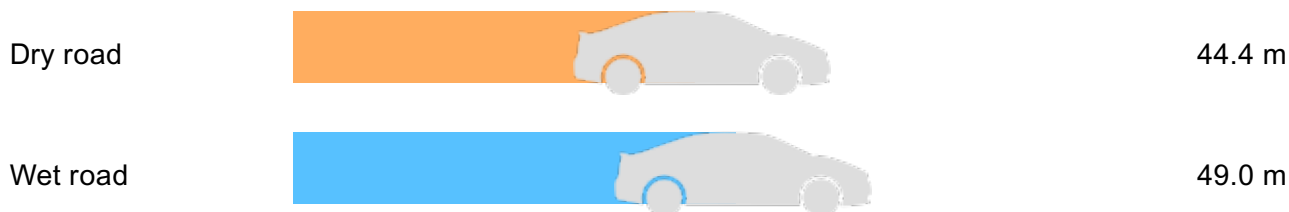

VEHICLE SPECIFICATION

| | | | |
|----------------|---|----------------|---|
| 1st gear ratio | 2.386 ~ 0.426: CONTINUOUSLY VARIABLE TRANSMISSION | 2nd gear ratio | - |
| 3rd gear ratio | - | 4th gear ratio | - |

| | | | |
|--|---|---------------------------------------|--------------------------------|
| 5th gear ratio | - | 6th gear ratio | - |
| Additional notes | AHEFK | Airbag position, capacity | - |
| Body rear overhang | 515 | Body type | BOX TYPE |
| Chassis number embossing position | ENGINE ROOM TOOL INSIDE COWL PANEL CENTRE ATTACHING CLOSE | Classification code | 0002 |
| Cylinders | 4 | Displacement | 1320 |
| Electric engine type | - | Electric engine maximum output | - |
| Electric engine maximum torque | - | Electric engine power | - |
| Engine maximum power | 70/6000(NET) | Engine maximum torque | 121/4000(NET) |
| Engine model | 1NR | Frame type | SOLID STRUCTURE |
| Front shaft weight | 600 | Front shock absorber type | |
| Front stabilizer type | - | Front tires size | 155/80R13 79S 165/70R14 81S |
| Front tread | 1.465 1.455 | Fuel consumption | 21.0 |
| Fuel tank equipment | 40 | Grade | 1.3 + HANA |
| Height | 1.535 | Length | 3.650 |
| Main brakes type | HYDRAULIC TYPE, FRONT DISK BACK LEADING TRAILING | Make | TOYOTA |
| Maximum speed | 170 | Minimum ground clearance | 0.140 |
| Minimum turning radius | 4.3 4.7 | Model | PASSO |
| Model code | DBA-NGC30 | Mufflers number | |
| Rear shaft weight | 340 | Rear shock absorber type | |

| | | | |
|-----------------------------|-------------|--------------------------|---|
| Rear stabilizer type | - | Rear tires size | 155/80R13 79S 165/70R14 81S |
| Rear tread | 1.475 1.465 | Reverse ratio | 2.505 |
| Riding capacity | 5 | Side brakes type | MACHINE CAR WHEEL制 動 SHAPE(DRUM TYPE) |
| Specification code | 16442 | Stopping distance | 65(100) |
| Transmission type | AT | Weight | 940 |
| Wheel alignment | 2WD | Wheelbase | 2.440 |
| Width | 1.665 | | |

AUCTION DATA

Date: 2022-05-12, Auction: MIRIVE Osaka, Lot #: 10049

| | | | |
|--------------------|--------------|----------------|-------|
| Date: | 2022-05-12 | Lot #: | 10049 |
| Auction name: | MIRIVE Osaka | Region: | Osaka |
| Make: | TOYOTA | Model: | PASSO |
| Reg. year: | 2010 | Mileage (km): | 29234 |
| Displacement (cc): | 1300 | Transmission: | AT |
| Color: | GREEN | Model code: | NGC30 |
| Result: | sold | Auction grade: | 4 |
| Problem type: | No problem | Problem scale: | None |
| Contaminated: | No | Airbag: | OK |

Date: 2022-10-19, Auction: JAA HAA, Lot #: 72377

| | | | |
|--------------------|-------------------|---------------|-------|
| Date: | 2022-10-19 | Lot #: | 72377 |
| Auction name: | JAA HAA | Region: | |
| Make: | TOYOTA | Model: | PASSO |
| Reg. year: | 2010 | Mileage (km): | 29240 |
| Displacement (cc): | 1300 | Transmission: | CAT |
| Color: | .. CHAIR METALLIC | Model code: | NGC30 |

| | | | |
|---------------|------------|----------------|------|
| Result: | available | Auction grade: | 4 |
| Problem type: | No problem | Problem scale: | None |
| Contaminated: | No | Airbag: | OK |

Date: 2023-05-31, Auction: CAA Chubu, Lot #: 36295

| | | | |
|--------------------|---------------------------|----------------|-------|
| Date: | 2023-05-31 | Lot #: | 36295 |
| Auction name: | CAA Chubu | Region: | Aichi |
| Make: | TOYOTA | Model: | PASSO |
| Reg. year: | 2010 | Mileage (km): | 33501 |
| Displacement (cc): | 1300 | Transmission: | CAT |
| Color: | GREEN | Model code: | NGC30 |
| Result: | sold | Auction grade: | 4 |
| Problem type: | No problem | Problem scale: | None |
| Contaminated: | No | Airbag: | OK |

PHOTOS AND AUCTION SHEETS

| | | | | | | |
|-----------------|---------------------|-------------------|------------|---------------|------------------|----------|
| [1829] 10049 | 初度登録 22 9 年 月 | 車名 ハッピ | ドア | グレード プラスハチ | 駆動 2WD 4WD | 評価点 4 |
| 大阪 | 型式 DBA-NGC30 | 排気量 1300 CC | 保証書 有・無 | 定員 5 | | |

| | | | | | | |
|---------------------|----|------------------|------------------------------|--------------------|----------|----|
| 走行 29234 2009 | S# | 車検 5 9 年 月 | 色 (Col.No) ライトグリーン 656 | 燃料 G・D・電気 (その他) | 外装 CB | 内装 |
|---------------------|----|------------------|------------------------------|--------------------|----------|----|

| | | | | | | | | | | | |
|-----------|-------------|------------------------|----|----|----|-----|-----|---|----|----|-----|
| シフト AT | エアコン AAC | リサイクル預託金 9,420 円 | PS | PW | AW | エアB | ABS | 革 | SR | ナビ | DTV |
|-----------|-------------|------------------------|----|----|----|-----|-----|---|----|----|-----|

| | | |
|--------|-------------|------------------------|
| <注意事項> | 名義期限 月 日 | <セールスポイント> ★エーガー買取車 |
| | 輸入車 | |
| | ディーラー・並行 | |
| | 左H・右H | |

< 検査員記入欄 >

Fガラス (キズ・飛石・ヒビ・リペア跡・X要)

内装 (キズ・汚れ・シミ・コグ・穴・キレ・破れ)

オーディオ (無し・穴) / タイヤ (スタッドレス)

2744101 XX (ネジ)

ドアミラーも 下廻りも

スマートキー車内

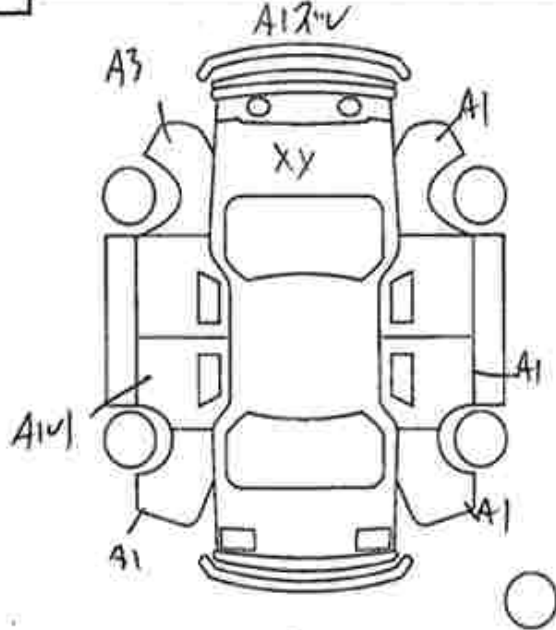

キーロック

ホイールCPキズ・ワレ/ドアミラーキズ・ワレ
小キズ有・小キズ有・補修有

| | | | | | | | |
|----|------|-------|-------|--------|------|----------------------|-----------------|
| 車種 | 取説 | ナビ取説 | DM/SD | B-CAS | リモコン | 登録番号 神戸531 可 2377 | 車台番号 0009904 |
| 品名 | ナンバー | スピーカー | キーレス | スマートキー | | | |











 **ネクステージ**



| | | | | | |
|-------|------|-----------|---------------|------------|-----------------|
| 出品番号 | 初度登録 | 車名 | ドア形状 | グレード | 評価点 |
| 36295 | H22年 | ハッソ | 5HB | プラスハナ | 4 |
| 初出品 | 9月 | 車歴 自家用 | 排気量 1300cc | 燃料 ガソリン | 型式 DBA-NGC30 |
| | | | | | 外装 C |
| | | | | | 内装 B |

| | | | | | |
|-----------|--------|--------------|-------|-----------------|--|
| 走行 | 車検 | 登録番号 | 名変期限 | セールスポイント | |
| 33,501 km | 05年09月 | 和歌山 501-4645 | 6月30日 | ★スマートキー ★ETC | |
| シフト | エアコン | 外装色 | 乗車定員 | 最大積載量 | |
| CAT | AAC | グリーン | 人 | kg | |
| | | カラーNo. | 輸入車 | リサイクル預託金 | |
| | | G50 | 系 | 9,420円 | |
| 後日発送部品 | | | | 純正装備 | |
| | | | | I7B アミ PS PW | |

| | | | | | |
|-------|--|---|---------------|--|--|
| 注意事項欄 | | | 車台番号 | | |
| | | | NGC30-0009904 | | |
| | | | 諸元 | | |
| 長さ | | 幅 | 高さ | | |

| |
|-----------------|
| 検査員記入欄 |
| 室内薄汚れ 外装小傷有り |
| 事務局よりご案内 |
| キーケース |

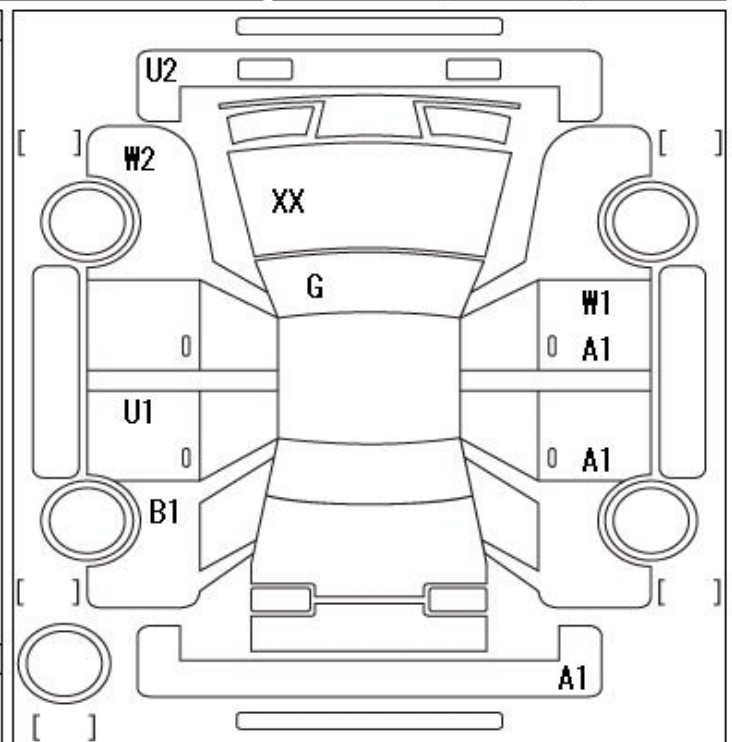

A:軽 U:AC B:軽を伴うAC P:要塗装 W:補修部 S:錆 C:腐食、穴 G:70%以上点検 XX:交換済み X:要交換 欠:欠品 内・外装評価 5段階5段階順(A・B・C・D・E) 1

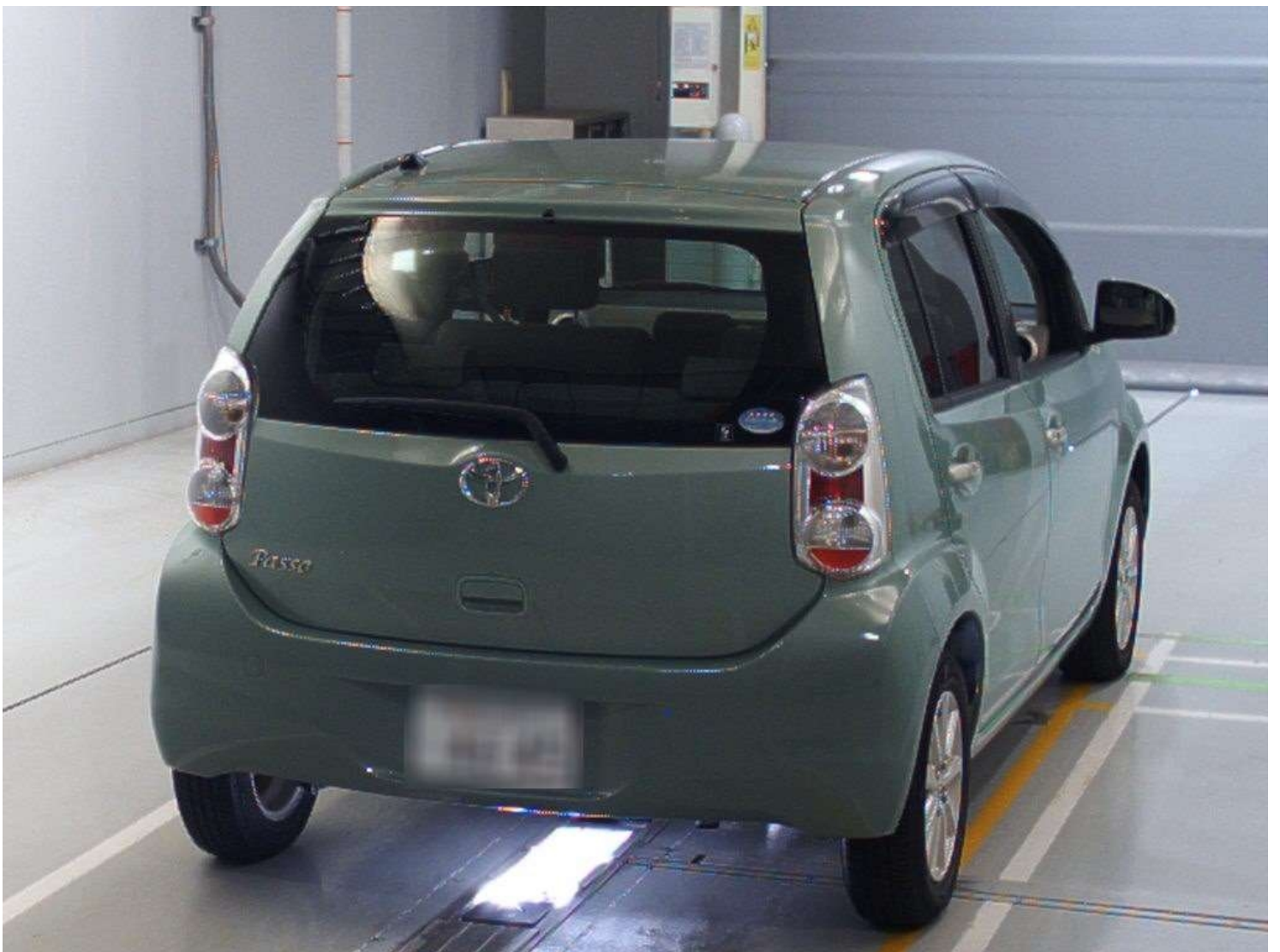











¹ Chassis number – a unique identification number of the vehicle in Japan (same as VIN in the USA or Europe)

² Title information:

Registered – qualified for driving in Japan

Deregistered Temporarily – not qualified for driving in Japan, usually a temporary title during the ownership change

Deregistered Completely – not qualified for driving in Japan, the vehicle is determined to be scrapped

Deregistered to Export – not qualified for driving in Japan, the vehicle is determined to be exported

³ Determining the overall collision safety performance evaluation – For the driver's seat, the results of the full-wrap frontal collision test, offset frontal collision test, and side collision test are added together and evaluated to 6 different levels. For the Frontal passenger's seat, the results of the full-wrap frontal collision test and the side collision test (results for the driver's or the front passenger's seat are used) are added together and evaluated to 6 different levels.

Regular vehicle inspection – All vehicles in Japan must undergo regular vehicle inspections (shaken). New cars need to be tested after three years, and then vehicles must be tested every two years thereafter. A vehicle inspection (shaken) is compulsory for all vehicles with an engine size over 250cc. It ensures that all vehicles on the road are properly maintained and safe to drive. The test also checks that vehicles have not been illegally modified; if they are found to have been modified, they are not allowed on the road.

⁴ Use in the contaminated regions – The Fukushima Daiichi nuclear disaster was a catastrophic failure at the Fukushima I Nuclear Power Plant on 11 March 2011, resulting in a meltdown of three of the plant's six nuclear reactors. As a result, some areas in the following prefectures were contaminated: Fukushima, Miyagi, Ibaraki, Tochigi.

⁵ Radioactive contamination test – radioactive contamination inspection that was started in July 2011 as a preventive measure for exporting contaminated vehicles from Japan. The inspection is being conducted since in all sea ports of Japan under the supervision of The Japan Harbor Transportation Association (JHTA).

MLIT – Ministry of Land, Infrastructure, Transport and Tourism.

⁶ Japan New Car Assessment Program – the Ministry of Land, Infrastructure, Transport and Tourism (MLIT) and the National Agency for Automotive Safety & Victims' Aid (NASVA) have taken measures for safety, one of which is to assess commercially available vehicles through a variety of safety performance tests and release the resulting information compiled into the "New Car Assessment Program". The objective of Japan New Car Assessment Program is to increase the use of safe automobiles by providing an environment in which users can easily select such vehicles. This also promotes the development of safer vehicles by automobile manufacturers. Neck injury protection for rear-end collision performance test, rear seat passenger's protection for frontal collision performance test, rear passenger's seat belt usability evaluation test and seat belt reminder for passengers evaluation test are started in FY2009.

⁷ Braking Performance Tests – Braking performance is determined by the shortness of the distance in which a vehicle can stop and the stability of the vehicle at the time of braking. This test is performed under wet and dry road conditions for a vehicle which has both a driver and a front passenger. The distance it takes for the vehicle to stop and the stability of the vehicle at the time of braking is evaluated for when the vehicle is stopped abruptly while traveling at a speed of 100km/h. The stopping distance and vehicle speed have been measured by using GPS since FY2009.

CAR VX, LTD DEPENDS ON ITS SOURCES FOR THE ACCURACY AND RELIABILITY OF ITS INFORMATION. THEREFORE, NO RESPONSIBILITY IS ASSUMED BY CAR VX, LTD OR ITS AGENTS FOR ERRORS OR OMISSIONS IN THIS REPORT. CAR VX, LTD FURTHER EXPRESSLY DISCLAIMS ALL WARRANTIES, EXPRESS OR IMPLIED, INCLUDING ANY IMPLIED WARRANTIES OF MERCHANTABILITY OR FITNESS FOR A PARTICULAR PURPOSE.

© 2014-2023 Car VX Limited. All rights reserved.