



# Vehicle History Report

## VEHICLE DETAILS

**Chassis number <sup>1</sup>:** WBAUS920X0A938592

**Manufacture date:** 2012

**Make:** BMW

**Model:** 320i TOURING

**Body:** LBA-US20

**Grade:** 320i TOURING

**Engine:** N43B20A

**Drive:** 2WD

**Transmission:** AT

**Title information <sup>2</sup>:**



**Deregistered to Export**



**Accident / Repair:**



**No problem**



**Odometer rollback:**



**No problem**



**Manufacturer recall:**



**No problem**



**Safety grade <sup>3</sup>:**



**No data**



**Contamination risk:**



**No problem**



**This vehicle does not qualify for Buyback Guarantee**

**Average Market Price**



Unfortunately, this vehicle does not qualify for our Buyback Guarantee program.



**¥350,000**

[About Buyback Guarantee](#)

This CAR VX Vehicle History Report is based only on Information supplied to CAR VX, LTD and available as of 2023-07-01 18:57:05. Other information about this vehicle, including problems, may not have been reported to CAR VX, LTD . Use this report as one important tool, along with a vehicle inspection and test drive, to make a better decision about your next used car.

## ACCIDENT / REPAIR HISTORY

Problem type	Reported	Date reported	Data source	Details	Airbag
Collision	Not reported				
Malfunction	Not reported				
Theft	Not reported				
Fire damage	Not reported				
Water damage	Not reported				
Hail damage	Not reported				

## ODOMETER READINGS HISTORY

Date reported	Data source	Odometer reading (Km)
2019-03-26	MLIT	50200
2021-04-19	MLIT	59300
2023-06-08	USS Tokyo	69600

## USE HISTORY

<b>Use in the contaminated regions <sup>4</sup></b>	<b>Radioactive contamination test fail <sup>5</sup></b>	<b>Commercial use</b>
Not reported	Not reported	Not reported

## DETAILED HISTORY

Event date	Location	Odometer reading (Km)	Data source	Details
2012			BMW	Manufactured
2012-04			MLIT	First registration
2019-03-26		50200	MLIT	Inspection
2021-04-19	Nerima	59300	MLIT	Inspection
2023-04-12	Nerima		MLIT	Last registration

## MANUFACTURER RECALL HISTORY

Date reported	Data source	Affected part	Details
---------------	-------------	---------------	---------

 Not reported

## VEHICLE ASSESSMENT <sup>6</sup>

### Overall Collision Safety Ratings

Driver's seat			Front passenger's seat		
Points	Evaluation	Goal average	Points	Evaluation	Goal average
0		0%	0		0%

\* In order to accurately differentiate between the evaluations of different vehicles, a standard is set based on current technology. Up to 6 points out of 12 is given level 1 and the rest of the range is divided up into equal parts, which are respectively assigned to level 2 (more than 6 points but 7.5 or less), level 3 (more than 7.5 points but 9 or less), level 4 (more than 9 points but 10.5 or less) or level 5 (more than 10.5 points).

### Braking performance tests <sup>7</sup>

Dry road



Wet road



## VEHICLE SPECIFICATION

1st gear ratio

2nd gear ratio

3rd gear ratio

4th gear ratio

5th gear ratio

6th gear ratio

Additional notes

Airbag position,  
capacity

Body rear overhang

Body type

WAGON

<b>Chassis number embossing position</b>		<b>Classification code</b>	2
<b>Cylinders</b>	4	<b>Displacement</b>	1990
<b>Electric engine type</b>		<b>Electric engine maximum output</b>	
<b>Electric engine maximum torque</b>		<b>Electric engine power</b>	
<b>Engine maximum power</b>	170ps(125kW)/6700rpm	<b>Engine maximum torque</b>	21.4kg·m(210N·m)/4250rpm
<b>Engine model</b>	N43B20A	<b>Frame type</b>	
<b>Front shaft weight</b>	770	<b>Front shock absorber type</b>	
<b>Front stabilizer type</b>		<b>Front tires size</b>	205/55R16
<b>Front tread</b>	1505	<b>Fuel consumption</b>	
<b>Fuel tank equipment</b>	60	<b>Grade</b>	320i TOURING
<b>Height</b>	143	<b>Length</b>	453
<b>Main brakes type</b>		<b>Make</b>	BMW
<b>Maximum speed</b>		<b>Minimum ground clearance</b>	
<b>Minimum turning radius</b>	5.3m	<b>Model</b>	320i TOURING
<b>Model code</b>	LBA-US20	<b>Mufflers number</b>	
<b>Rear shaft weight</b>	810	<b>Rear shock absorber type</b>	
<b>Rear stabilizer type</b>		<b>Rear tires size</b>	205/55R16
<b>Rear tread</b>	1535	<b>Reverse ratio</b>	
<b>Riding capacity</b>	5	<b>Side brakes type</b>	
<b>Specification code</b>	16532	<b>Stopping distance</b>	
<b>Transmission type</b>	AT	<b>Weight</b>	1580
<b>Wheel alignment</b>	2WD	<b>Wheelbase</b>	2760
<b>Width</b>	180		

**Date: 2023-06-08, Auction: USS Tokyo, Lot #: 73407**

Date:	2023-06-08	Lot #:	73407
Auction name:	<a href="#">USS Tokyo</a>	Region:	Chiba
Make:	BMW	Model:	3 SERIES
Reg. year:	2012	Mileage (km):	69600
Displacement (cc):	2000	Transmission:	AT
Color:	WHITE	Model code:	US20
Result:	available	Auction grade:	4
Problem type:	No problem	Problem scale:	None
Contaminated:	No	Airbag:	OK

**PHOTOS AND AUCTION SHEETS**

# 輸入車ドイコーナー

73407	車種 (自家用以外は記入)	排気量	型式	評価点 <b>4</b>	
		2000	LBA-US20		
初年度登録年月	車名	グレード	駆動	内装 B	
H24/4月	BMW 3シリーズ	320i ツーリング ハイラインパッケージ	ZND		
車検	年 月 日	シフト	FAT	SR カフ	
走行	69,600 km	冷房	AC	NAV TV	
外色	色別	カラー別		PS ナビ	
白色	ホワイト	300		PA エアロ	
燃料	ガソリン	内装色		セールスポイント 革シート ミラーETC	
型式	輸入区分	ハンドル		*詳細と一緒に掲載下さい。	
	ディーラー	右	月 日	名義変更済	
リサイクル 販売金	18,770円	乗車定員	5人	登録No.	
○注意事項 (※必ず不具合箇所を記入して下さい)				車台No.	WBAUS920X0A938592
				シリアルNo.	

## ○検査員報告

- トリムキズ
- ルーム内スレ汚れ
- ホイールキズ
- Dミラーキズ
- 各キズ凹

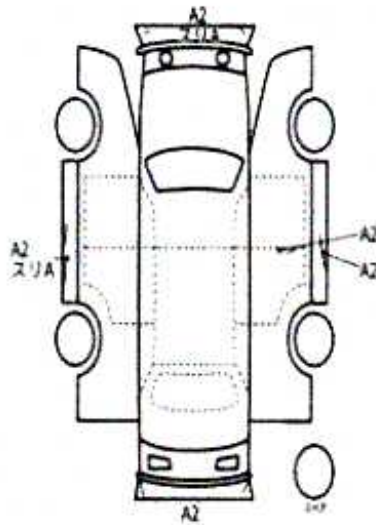

【乗台内寸】約      x      x      (cm)  
長さ 453 cm 幅 180 cm 高さ 143 cm





**<sup>1</sup> Chassis number** – a unique identification number of the vehicle in Japan (same as VIN in the USA or Europe)

**<sup>2</sup> Title information:**

Registered – qualified for driving in Japan

Deregistered Temporarily – not qualified for driving in Japan, usually a temporary title during the ownership change

Deregistered Completely – not qualified for driving in Japan, the vehicle is determined to be scrapped

Deregistered to Export – not qualified for driving in Japan, the vehicle is determined to be exported

**<sup>3</sup> Determining the overall collision safety performance evaluation** – For the driver's seat, the results of the full-wrap frontal collision test, offset frontal collision test, and side collision test are added together and evaluated to 6 different levels. For the Frontal passenger's seat, the results of the full-wrap frontal collision test and the side collision test (results for the driver's or the front passenger's seat are used) are added together and evaluated to 6 different levels.

Regular vehicle inspection – All vehicles in Japan must undergo regular vehicle inspections (shaken). New cars need to be tested after three years, and then vehicles must be tested every two years thereafter. A vehicle inspection (shaken) is compulsory for all vehicles with an engine size over 250cc. It ensures that all vehicles on the road are properly maintained and safe to drive. The test also checks that vehicles have not been illegally modified; if they are found to have been modified, they are not allowed on the road.

**<sup>4</sup> Use in the contaminated regions** – The Fukushima Daiichi nuclear disaster was a catastrophic failure at the Fukushima I Nuclear Power Plant on 11 March 2011, resulting in a meltdown of three of the plant's six nuclear reactors. As a result, some areas in the following prefectures were contaminated: Fukushima, Miyagi, Ibaraki, Tochigi.

**<sup>5</sup> Radioactive contamination test** – radioactive contamination inspection that was started in July 2011 as a preventive measure for exporting contaminated vehicles from Japan. The inspection is being conducted since in all sea ports of Japan under the supervision of The Japan Harbor Transportation Association (JHTA).

MLIT – Ministry of Land, Infrastructure, Transport and Tourism.

**<sup>6</sup> Japan New Car Assessment Program** – the Ministry of Land, Infrastructure, Transport and Tourism (MLIT) and the National Agency for Automotive Safety & Victims' Aid (NASVA) have taken measures for safety, one of which is to assess commercially available vehicles through a variety of safety performance tests and release the resulting information compiled into the "New Car Assessment Program". The objective of Japan New Car Assessment Program is to increase the use of safe automobiles by providing an environment in which users can easily select such vehicles. This also promotes the development of safer vehicles by automobile manufacturers. Neck injury protection for rear-end collision performance test, rear seat passenger's protection for frontal collision performance test, rear passenger's seat belt usability evaluation test and seat belt reminder for passengers evaluation test are started in FY2009.

**<sup>7</sup> Braking Performance Tests** – Braking performance is determined by the shortness of the distance in which a vehicle can stop and the stability of the vehicle at the time of braking. This test is performed under wet and dry road conditions for a vehicle which has both a driver and a front passenger. The distance it takes for the vehicle to stop and the stability of the vehicle at the time of braking is evaluated for when the vehicle is stopped abruptly while traveling at a speed of 100km/h. The stopping distance and vehicle speed have been measured by using GPS since FY2009.



CAR VX, LTD DEPENDS ON ITS SOURCES FOR THE ACCURACY AND RELIABILITY OF ITS INFORMATION. THEREFORE, NO RESPONSIBILITY IS ASSUMED BY CAR VX, LTD OR ITS AGENTS FOR ERRORS OR OMISSIONS IN THIS REPORT. CAR VX, LTD FURTHER EXPRESSLY DISCLAIMS ALL WARRANTIES, EXPRESS OR IMPLIED, INCLUDING ANY IMPLIED WARRANTIES OF MERCHANTABILITY OR FITNESS FOR A PARTICULAR PURPOSE.

© 2014-2023 Car VX Limited. All rights reserved.