



Vehicle History Report

VEHICLE DETAILS

Chassis number ¹: GGH25-8012779

Manufacture date: 2010-02

Make: TOYOTA

Model: VELLFIRE

Body: DBA-GGH25W

Grade: 3.5V L EDITION

Engine: 2GR-FE

Drive: 4WD

Transmission: AT

Title information ²:  **Registered** 

Accident / Repair:  **No problem** 

Odometer rollback:  **No problem** 

Manufacturer recall:  **No problem** 

Safety grade ³:  **★★★★★** 

Contamination risk:  **Problem found** 

This vehicle does not qualify for Buyback Guarantee

Average Market Price



Unfortunately, this vehicle does not qualify for our Buyback Guarantee program.

 **¥0**

[About Buyback Guarantee](#)

This CAR VX Vehicle History Report is based only on Information supplied to CAR VX, LTD and available as of 2023-08-02 01:21:13. Other information about this vehicle, including problems, may not have been reported to CAR VX, LTD . Use this report as one important tool, along with a vehicle inspection and test drive, to make a better decision about your next used car.

ACCIDENT / REPAIR HISTORY

Problem type	Reported	Date reported	Data source	Details	Airbag
Collision	Not reported				
Malfunction	Not reported				
Theft	Not reported				
Fire damage	Not reported				
Water damage	Not reported				
Hail damage	Not reported				

ODOMETER READINGS HISTORY

Date reported	Data source	Odometer reading (Km)
2014-04-05	HAA Kobe	29330
2021-03-30	MLIT	60600
2023-03-31	MLIT	71900
2023-07-26	USS Tohoku	73434
2023-07-26	Guliver Oneprice	73434

USE HISTORY

Use in the contaminated regions ⁴	Radioactive contamination test fail ⁵	Commercial use
Reported	Not reported	Not reported

DETAILED HISTORY

Event date	Location	Odometer reading (Km)	Data source	Details
2010-02			TOYOTA	Manufactured
2010-02			MLIT	First registration
2014-04-05	Hyogo	29330	HAA Kobe	Auctioned

2020-11-20	Hachinohe		MLIT	Last registration
2021-03-30		60600	MLIT	Inspection
2023-03-31	Hachinohe	71900	MLIT	Inspection
2023-07-26	Miyagi	73434	USS Tohoku	Auctioned
2023-07-26		73434	Guliver Oneprice	Auctioned

MANUFACTURER RECALL HISTORY

Date reported	Data source	Affected part	Details
 Not reported			

VEHICLE ASSESSMENT ⁶

Overall Collision Safety Ratings

Driver's seat			Front passenger's seat		
Points	Evaluation	Goal average	Points	Evaluation	Goal average
34.46	★★★★★★	96%	23.51	★★★★★★	98%

* In order to accurately differentiate between the evaluations of different vehicles, a standard is set based on current technology. Up to 6 points out of 12 is given level 1 and the rest of the range is divided up into equal parts, which are respectively assigned to level 2 (more than 6 points but 7.5 or less), level 3 (more than 7.5 points but 9 or less), level 4 (more than 9 points but 10.5 or less) or level 5 (more than 10.5 points).

Braking performance tests ⁷

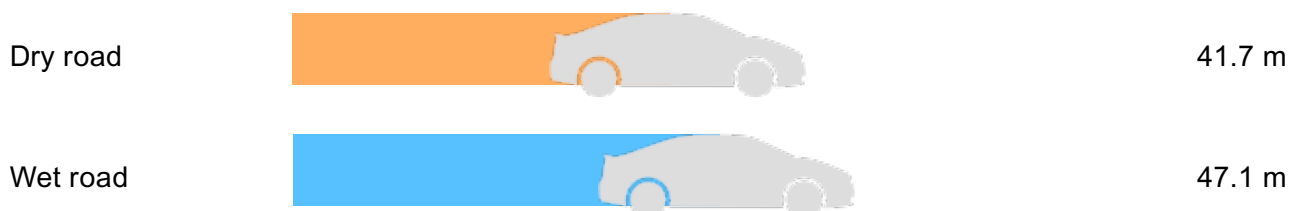

VEHICLE SPECIFICATION

1st gear ratio	3.300	2nd gear ratio	1.900
3rd gear ratio	1.420	4th gear ratio	1.000

5th gear ratio	0.713	6th gear ratio	0.608
Additional notes	NFTQK	Airbag position, capacity	-
Body rear overhang	1015	Body type	MV&1BOX
Chassis number embossing position	FRONT FLOOR CROSSMEMBER RIGHT SIDE ON SURFACE	Classification code	0006
Cylinders	V6 WIDTH	Displacement	3450
Electric engine type	-	Electric engine maximum output	-
Electric engine maximum torque	-	Electric engine power	-
Engine maximum power	206/6200(NET)	Engine maximum torque	344/4700(NET)
Engine model	2GR-FE	Frame type	SOLID STRUCTURE
Front shaft weight	1160	Front shock absorber type	
Front stabilizer type	TORSION BAR TYPE	Front tires size	215/65R16 98H
Front tread	1580	Fuel consumption	9.1
Fuel tank equipment	65	Grade	3.5V L EDITION
Height	1905	Length	4850
Main brakes type	HYDRAULIC TYPE, DISK HYDRAULIC TYPE, DISK	Make	TOYOTA
Maximum speed	180	Minimum ground clearance	170
Minimum turning radius	5.7	Model	VELLFIRE
Model code	DBA-GGH25W	Mufflers number	
Rear shaft weight	940	Rear shock absorber type	
Rear stabilizer type	-	Rear tires size	215/65R16 98H
Rear tread	1585	Reverse ratio	4.148
Riding capacity	7	Side brakes type	MACHINE CAR WHEEL SHAPE(DRUM TYPE)

Specification code	16089	Stopping distance	50(100)
Transmission type	AT	Weight	2100
Wheel alignment	4WD	Wheelbase	2950
Width	1830		

AUCTION DATA

Date: 2014-04-05, Auction: HAA Kobe, Lot #: 55744

Date:	2014-04-05	Lot #:	55744
Auction name:	HAA Kobe	Region:	Hyogo
Make:	TOYOTA	Model:	VELLFIRE
Reg. year:	2010	Mileage (km):	29330
Displacement (cc):	3500	Transmission:	AT
Color:	PEARL	Model code:	GGH25W
Result:	unsold	Auction grade:	5
Problem type:	No problem	Problem scale:	None
Contaminated:	No	Airbag:	OK

Date: 2023-07-26, Auction: Guliver Oneprice, Lot #: 14061

Date:	2023-07-26	Lot #:	14061
Auction name:	Guliver Oneprice	Region:	
Make:	TOYOTA	Model:	VELLFIRE
Reg. year:	2010	Mileage (km):	73434
Displacement (cc):	3500	Transmission:	IAT
Color:	PEARL	Model code:	GGH25W
Result:	available	Auction grade:	4
Problem type:	No problem	Problem scale:	None
Contaminated:	No	Airbag:	OK

Date: 2023-07-26, Auction: USS Tohoku, Lot #: 6034

Date:	2023-07-26	Lot #:	6034
Auction name:	USS Tohoku	Region:	Miyagi
Make:	TOYOTA	Model:	VELLFIRE
Reg. year:	2010	Mileage (km):	73434
Displacement (cc):	3500	Transmission:	IA
Color:	PEARL	Model code:	GGH25W
Result:	available	Auction grade:	4
Problem type:	No problem	Problem scale:	None
Contaminated:	Yes	Airbag:	OK

PHOTOS AND AUCTION SHEETS

出品番号 55744	初年度登録年月 22/2月	車名 ヴェルファイア	ドア形状 5W	グレード 3.5V Lエディション	評価点 5
車歴	型式 DBA-GGH25W	排気量 3500cc	燃料 2WD・軽油()		

車検 27年04月	707	AT	セールスポイント ユーザー買取車!!	外装 A	内装 A
走行 29330 km	コラム		アリババ社外せ&後モーター	B	B
メーター交換歴 \$交換車 *改竄車 #不明車	インパネ	速	スタートキー、ETC、赤電格付	C	C
外装色 パール	色替		電動リアゲート!!	D	D
カラーNo 070	内装色 ベージュ			E	E
車台番号 GGH25-8012779	冷房 AAC	無	純正 PS (パワーステアリング)	ABS	ABS
定員(7)名 福祉車両装備			純正 の丸印	純正ナビ	純正TV
輸入車 ディーラー・並行	ハンドル 左H・右H	モデル年式()年	純正 の丸印	純正ナビ	純正TV

注意事項
 運転席、助手席、2列目バックシート88
 助手席、2列目フロントシート88 シートヒーター88
 フロント両サイド、バックカメラ88 両側SD
 ※リサイクル料金は別途見積り
 18,290円

ハンドル	シート	オーディオ	ホイール	エアロ	ドアミラー
A・スレ	A・スレ	無し・穴	A・ワレ	A・ワレ	A・ワレ
FW	A)リペア・ワレ	室内シート	コゲ・穴・汚れ・キズ・破れ		

希望品 ユーザ プレミアム	希望品 乗用車 ニバン	希望品 乗用車 バン	希望品 乗用車 軽四	希望品 乗用車 軽四	希望品 乗用車 輸入車
プロック NEXT	プロック フレッシュ	プロック フレッシュ	プロック フレッシュ	プロック フレッシュ	プロック フレッシュ

新車保証書 取扱説明書

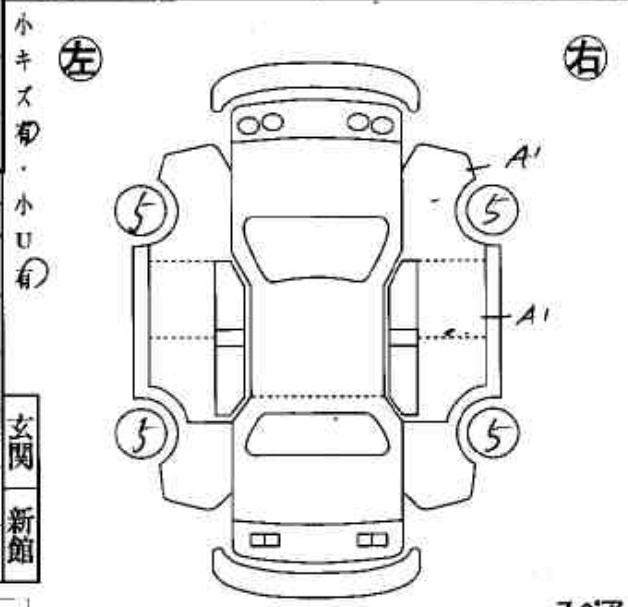

小キズ有・小凹有
 玄関 新館
 スペア
 取・無
 神戸 330 な 8031





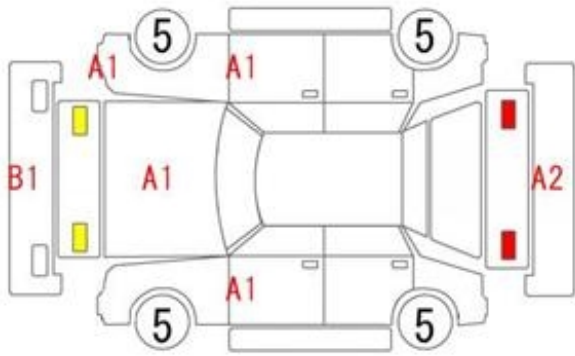



Gulliver



フレッシュコーナー

6034	車種 (自動車以外は記入) 積重量	型式	戸数
	22/2月 7月7日	3,500	AAA-GGH25W.
	初年度登録年月 車名	燃料 クレード	2WD
	22/2月 7月7日	AW 3.5V	
		5 L277777	内装 色 B

車種	R7年 4月	シフト	IAT	AW	AW	ナビ	ナビ
走行	73,434	冷房	NAC	セールスポイント			
外色	色別	カラー		*本外ナビ付			
内色	10-IL	070		*本外ナビ付			
燃料	ガソリン	駆動方式		*本外ナビ付			
年式	7年	登録		*本外ナビ付			
車名	ディーラー	走行	左				

リサイクル	18,290	乗車定員	7人	登録	8戸	300	80
保証					車台	GGH25-8012779	
注意事項 (車検 不具合箇所あり)				シリアル			

★2-7-夏車
★両側ナビ付
★システムナビ付
★ナビ付
★ナビ付

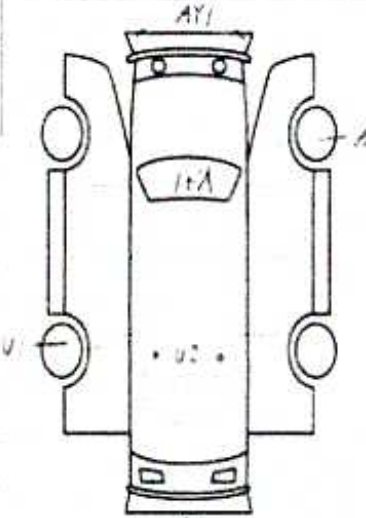

シート
汚れ
ホイール
一部ナビ
合メ

車載品預り

【荷台内寸】約 X X (mm)
長さ 485mm 幅 182mm 高さ 190mm (車検証上の寸法)





¹ Chassis number – a unique identification number of the vehicle in Japan (same as VIN in the USA or Europe)

² Title information:

Registered – qualified for driving in Japan

Deregistered Temporarily – not qualified for driving in Japan, usually a temporary title during the ownership change

Deregistered Completely – not qualified for driving in Japan, the vehicle is determined to be scrapped

Deregistered to Export – not qualified for driving in Japan, the vehicle is determined to be exported

³ Determining the overall collision safety performance evaluation – For the driver's seat, the results of the full-wrap frontal collision test, offset frontal collision test, and side collision test are added together and evaluated to 6 different levels. For the Frontal passenger's seat, the results of the full-wrap frontal collision test and the side collision test (results for the driver's or the front passenger's seat are used) are added together and evaluated to 6 different levels.

Regular vehicle inspection – All vehicles in Japan must undergo regular vehicle inspections (shaken). New cars need to be tested after three years, and then vehicles must be tested every two years thereafter. A vehicle inspection (shaken) is compulsory for all vehicles with an engine size over 250cc. It ensures that all vehicles on the road are properly maintained and safe to drive. The test also checks that vehicles have not been illegally modified; if they are found to have been modified, they are not allowed on the road.

⁴ Use in the contaminated regions – The Fukushima Daiichi nuclear disaster was a catastrophic failure at the Fukushima I Nuclear Power Plant on 11 March 2011, resulting in a meltdown of three of the plant's six nuclear reactors. As a result, some areas in the following prefectures were contaminated: Fukushima, Miyagi, Ibaraki, Tochigi.

⁵ Radioactive contamination test – radioactive contamination inspection that was started in July 2011 as a preventive measure for exporting contaminated vehicles from Japan. The inspection is being conducted since in all sea ports of Japan under the supervision of The Japan Harbor Transportation Association (JHTA).

MLIT – Ministry of Land, Infrastructure, Transport and Tourism.

⁶ Japan New Car Assessment Program – the Ministry of Land, Infrastructure, Transport and Tourism (MLIT) and the National Agency for Automotive Safety & Victims' Aid (NASVA) have taken measures for safety, one of which is to assess commercially available vehicles through a variety of safety performance tests and release the resulting information compiled into the "New Car Assessment Program". The objective of Japan New Car Assessment Program is to increase the use of safe automobiles by providing an environment in which users can easily select such vehicles. This also promotes the development of safer vehicles by automobile manufacturers. Neck injury protection for rear-end collision performance test, rear seat passenger's protection for frontal collision performance test, rear passenger's seat belt usability evaluation test and seat belt reminder for passengers evaluation test are started in FY2009.

⁷ Braking Performance Tests – Braking performance is determined by the shortness of the distance in which a vehicle can stop and the stability of the vehicle at the time of braking. This test is performed under wet and dry road conditions for a vehicle which has both a driver and a front passenger. The distance it takes for the vehicle to stop and the stability of the vehicle at the time of braking is evaluated for when the vehicle is stopped abruptly while traveling at a speed of 100km/h. The stopping distance and vehicle speed have been measured by using GPS since FY2009.

CAR VX, LTD DEPENDS ON ITS SOURCES FOR THE ACCURACY AND RELIABILITY OF ITS INFORMATION. THEREFORE, NO RESPONSIBILITY IS ASSUMED BY CAR VX, LTD OR ITS AGENTS FOR ERRORS OR OMISSIONS IN THIS REPORT. CAR VX, LTD FURTHER EXPRESSLY DISCLAIMS ALL WARRANTIES, EXPRESS OR IMPLIED, INCLUDING ANY IMPLIED WARRANTIES OF MERCHANTABILITY OR FITNESS FOR A PARTICULAR PURPOSE.

© 2014-2023 Car VX Limited. All rights reserved.